



### General Description

PSoC<sup>®</sup> 4 is a scalable and reconfigurable platform architecture for a family of mixed-signal programmable embedded system controllers with an ARM<sup>®</sup> Cortex<sup>™</sup>-M0 CPU. It combines programmable and re-configurable analog and digital blocks with flexible automatic routing. The PSoC 4200 product family, based on this platform, is a combination of a microcontroller with digital programmable logic, high-performance analog-to-digital conversion, opamps with Comparator mode, and standard communication and timing peripherals. The PSoC 4200 products will be fully upward compatible with members of the PSoC 4 platform for new applications and design needs. The programmable analog and digital sub-systems allow flexibility and in-field tuning of the design.

### Features

#### 32-bit MCU Sub-system

- 48 MHz ARM Cortex-M0 CPU with single cycle multiply
- Up to 32 kB of flash with Read Accelerator
- Up to 4 kB of SRAM

#### Programmable Analog

- Two opamps with reconfigurable high-drive external and high-bandwidth internal drive, Comparator modes, and ADC input buffering capability
- 12-bit, 1-Msps SAR ADC with differential and single-ended modes; Channel Sequencer with signal averaging
- Two current DACs (IDACs) for general-purpose or capacitive sensing applications on any pin
- Two low-power comparators that operate in Deep Sleep

#### Programmable Digital

- Four programmable logic blocks called universal digital blocks, (UDBs), each with 8 Macrocells and data path
- Cypress-provided peripheral component library, user-defined state machines, and Verilog input

#### Low Power 1.71 to 5.5 V operation

- 20-nA Stop Mode with GPIO pin wakeup
- Hibernate and Deep Sleep modes allow wakeup-time versus power trade-offs

#### Capacitive Sensing

- Cypress Capacitive Sigma-Delta (CSD) provides best-in-class SNR (>5:1) and water tolerance
- Cypress-supplied software component makes capacitive sensing design easy
- Automatic hardware tuning (SmartSense<sup>™</sup>)

#### Segment LCD Drive

- LCD drive supported on all pins (common or segment)
- Operates in Deep Sleep mode with 4 bits per pin memory

#### Serial Communication

- Two independent run-time reconfigurable serial communication blocks (SCBs) with re-configurable I2C, SPI, or UART functionality

#### Timing and Pulse-Width Modulation

- Four 16-bit Timer/Counter Pulse-Width Modulator (TCPWM) blocks
- Center-aligned, Edge, and Pseudo-random modes
- Comparator-based triggering of Kill signals for motor drive and other high-reliability digital logic applications

#### Up to 36 Programmable GPIOs

- 44-pin TQFP, 40-pin QFN, and 28-pin SSOP packages.
- Any GPIO pin can be Capsense, LCD, analog, or digital
- Drive modes, strengths, and slew rates are programmable

#### PSoC Creator Design Environment

- Integrated Development Environment (IDE) provides schematic design entry and build (with analog and digital automatic routing)
- Applications Programming Interface (API) component for all fixed-function and programmable peripherals

#### Industry-Standard Tool Compatibility

- After schematic entry, development can be done with ARM-based industry-standard development tools

**Contents**

<b>Functional Definition</b> .....	<b>4</b>	Analog Peripherals .....	18
CPU and Memory Subsystem .....	4	Digital Peripherals .....	22
System Resources .....	4	Memory .....	25
Analog Blocks .....	5	System Resources .....	26
Programmable Digital .....	6	<b>Ordering Information</b> .....	<b>30</b>
Fixed Function Digital .....	7	Part Numbering Conventions .....	31
GPIO .....	7	<b>Packaging</b> .....	<b>32</b>
Special Function Peripherals .....	8	<b>Acronyms</b> .....	<b>34</b>
<b>Pinouts</b> .....	<b>9</b>	<b>Document Conventions</b> .....	<b>36</b>
<b>Power</b> .....	<b>12</b>	Units of Measure .....	36
Unregulated External Supply.....	12	<b>Revision History</b> .....	<b>37</b>
Regulated External Supply .....	12	<b>Sales, Solutions, and Legal Information</b> .....	<b>38</b>
<b>Development Support</b> .....	<b>13</b>	Worldwide Sales and Design Support .....	38
Documentation .....	13	Products .....	38
Online .....	13	PSoC <sup>®</sup> Solutions .....	38
Tools.....	13	Cypress Developer Community.....	38
<b>Electrical Specifications</b> .....	<b>14</b>	Technical Support .....	38
Absolute Maximum Ratings .....	14		
Device Level Specifications .....	14		

Figure 1. Block Diagram

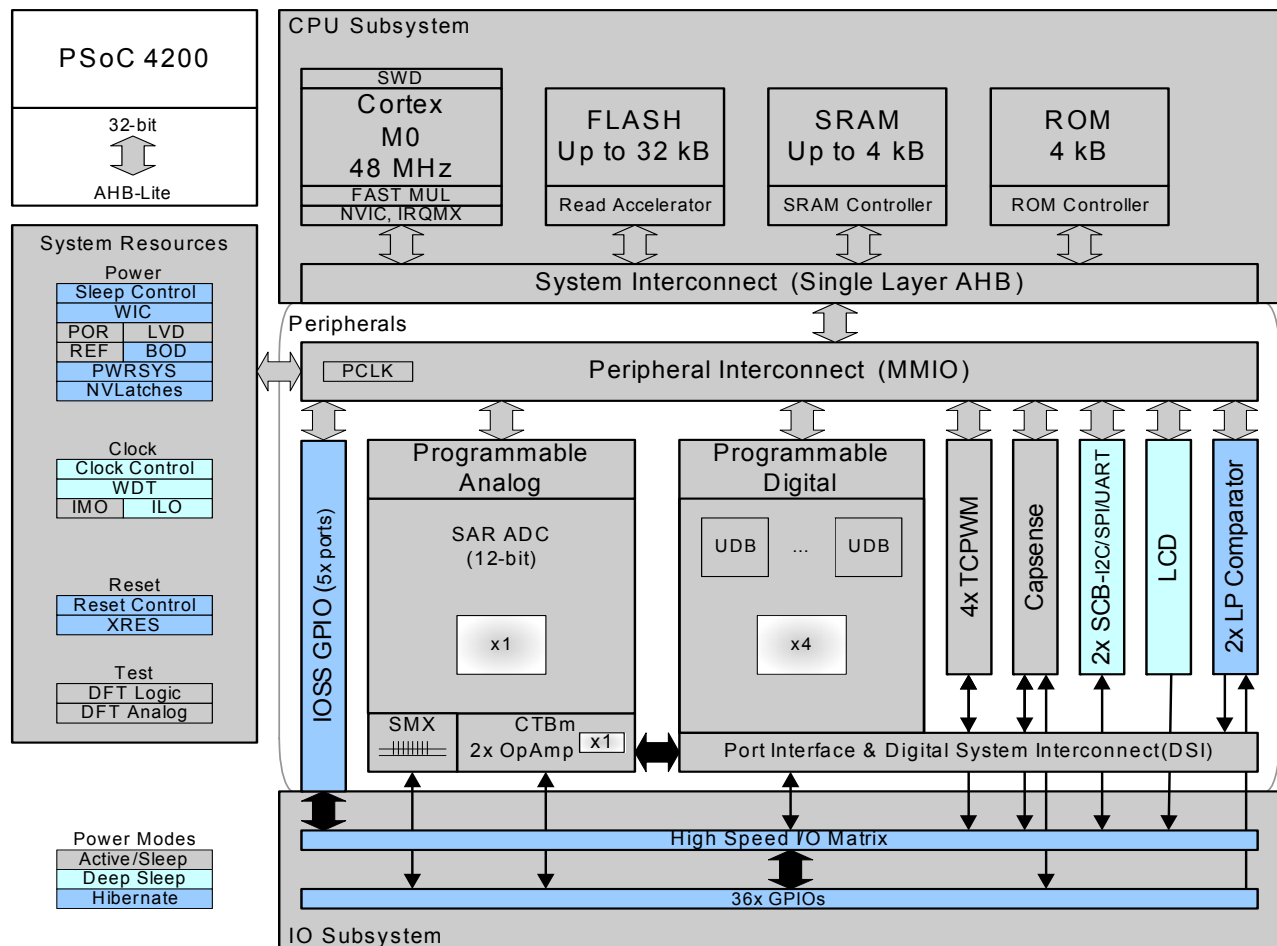

The PSoC 4200 devices include extensive support for programming, testing, debugging, and tracing both hardware and firmware.

The ARM Serial\_Wire Debug (SWD) interface supports all programming and debug features of the device.

Complete debug-on-chip functionality enables full-device debugging in the final system using the standard production device. It does not require special interfaces, debugging pods, simulators, or emulators. Only the standard programming connections are required to fully support debug.

The PSoC Creator IDE provides fully integrated programming and debug support for the PSoC 4200 devices. The SWD interface is fully compatible with industry-standard third-party tools. With the ability to disable debug features, with very robust flash protection, and allowing customer-proprietary functionality to be implemented in on-chip programmable blocks, the

PSoC 4200 family provides a level of security not possible with multi-chip application solutions or with microcontrollers.

The debug circuits are enabled by default and can only be disabled in firmware. If not enabled, the only way to re-enable them is to erase the entire device, clear flash protection, and reprogram the device with new firmware that enables debugging.

Additionally, all device interfaces can be permanently disabled (device security) for applications concerned about phishing attacks due to a maliciously reprogrammed device or attempts to defeat security by starting and interrupting flash programming sequences. Because all programming, debug, and test interfaces are disabled when maximum device security is enabled, PSoC 4200 with device security enabled may not be returned for failure analysis. This is a trade-off the PSoC 4200 allows the customer to make.

## Functional Definition

### CPU and Memory Subsystem

#### CPU

The Cortex-M0 CPU in the PSoC 4200 is part of the 32-bit MCU subsystem, which is optimized for low-power operation with extensive clock gating. It mostly uses 16-bit instructions and executes a subset of the Thumb-2 instruction set. This enables fully compatible binary upward migration of the code to higher performance processors such as the Cortex-M3 and M4, thus enabling upward compatibility. The Cypress implementation includes a hardware multiplier that provides a 32-bit result in one cycle. It includes a nested vectored interrupt controller (NVIC) block with 32 interrupt inputs and also includes a Wakeup Interrupt Controller (WIC). The WIC can wake the processor up from the Deep Sleep mode, allowing power to be switched off to the main processor when the chip is in the Deep Sleep mode. The Cortex-M0 CPU provides a Non-Maskable Interrupt (NMI) input, which is made available to the user when it is not in use for system functions requested by the user.

The CPU also includes a debug interface, the serial wire debug (SWD) interface, which is a 2-wire form of JTAG; the debug configuration used for PSoC 4200 has four break-point (address) comparators and two watchpoint (data) comparators.

#### Flash

The PSoC 4200 device has a flash module with a flash accelerator, tightly coupled to the CPU to improve average access times from the flash block. The flash block is designed to deliver 1 wait-state (WS) access time at 48 MHz and with 0-WS access time at 24 MHz. The flash accelerator delivers 85% of single-cycle SRAM access performance on average. Part of the flash module can be used to emulate EEPROM operation if required.

#### SRAM

SRAM memory is retained during Hibernate.

#### SRAM

A supervisory ROM that contains boot and configuration routines is provided.

### System Resources

#### Power System

The power system is described in detail in the section [Power on page 12](#). It provides assurance that voltage levels are as required for each respective mode and either delay mode entry (on power-on reset (POR), for example) until voltage levels are as required for proper function or generate resets (Brown-Out Detect (BOD)) or interrupts (Low Voltage Detect (LVD)). The PSoC 4200 operates with a single external supply over the range of 1.71 to 5.5 V and has five different power modes, transitions between which are managed by the power system. The PSoC 4200 provides Sleep, Deep Sleep, Hibernate, and Stop low-power modes.

#### Clock System

The PSoC 4200 clock system is responsible for providing clocks to all subsystems that require clocks and for switching between different clock sources without glitching. In addition, the clock system ensures that no metastable conditions occur.

The clock system for the PSoC 4200 consists of the IMO and the ILO internal oscillators and provision for an external clock.

**Figure 2. PSoC 4200 MCU Clocking Architecture**

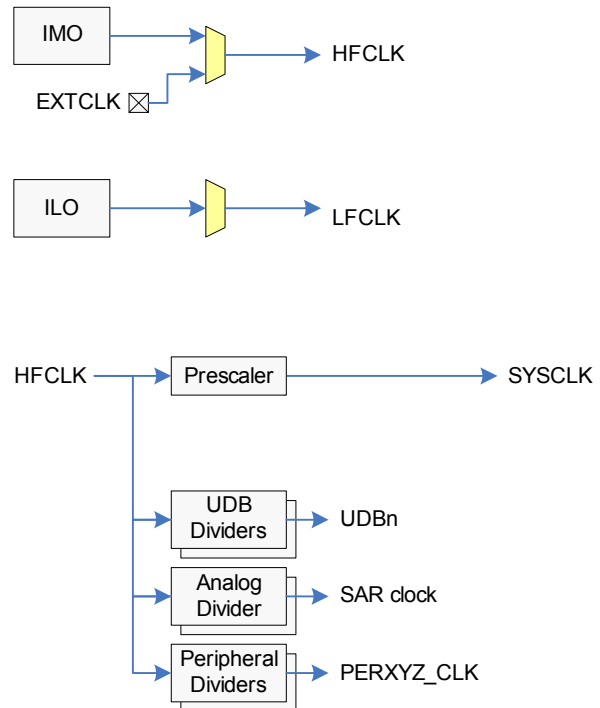

The HFCLK signal can be divided down (see [PSoC 4200 MCU Clocking Architecture](#)) to generate synchronous clocks for the UDBs, and the analog and digital peripherals. There are a total of 12 clock dividers for the PSoC 4200, each with 16-bit divide capability; this allows eight to be used for the fixed-function blocks and four for the UDBs. The analog clock leads the digital clocks to allow analog events to occur before digital clock-related noise is generated. The 16-bit capability allows a lot of flexibility in generating fine-grained frequency values and is fully supported in PSoC Creator. When UDB-generated Pulse Interrupts are used, SYSCLK must equal HFCLK.

**IMO Clock Source**

The IMO is the primary source of internal clocking in the PSoC 4200. It is trimmed during testing to achieve the specified accuracy. Trim values are stored in nonvolatile latches (NVL). Additional trim settings from flash can be used to compensate for changes. The IMO default frequency is 24 MHz and it can be adjusted between 3 to 48 MHz in steps of 1 MHz. IMO Tolerance with Cypress-provided calibration settings is  $\pm 2\%$ .

**ILO Clock Source**

The ILO is a very low power oscillator, which is primarily used to generate clocks for peripheral operation in Deep Sleep mode. ILO-driven counters can be calibrated to the IMO to improve accuracy. Cypress provides a software component, which does the calibration.

**Watchdog Timer**

A watchdog timer is implemented in the clock block running from the ILO; this allows watchdog operation during Deep Sleep and generates a watchdog reset if not serviced before the timeout occurs. The watchdog reset is recorded in the Reset Cause register.

**Reset**

The PSoC 4200 can be reset from a variety of sources including a software reset. Reset events are asynchronous and guarantee reversion to a known state. The reset cause is recorded in a register, which is sticky through reset and allows software to determine the cause of the Reset. An XRES pin is reserved for external reset to avoid complications with configuration and multiple pin functions during power-on or reconfiguration. The XRES pin has an internal pull-up resistor that is always enabled.

**Voltage Reference**

The PSoC 4200 reference system generates all internally required references. A 1% voltage reference spec is provided for the 12-bit ADC. To allow better signal to noise ratios (SNR) and better absolute accuracy, it is possible to bypass the internal reference using a GPIO pin or to use an external reference for the SAR.

**Analog Blocks**

**12-bit SAR ADC**

The 12-bit 1 MSample/second SAR ADC can operate at a maximum clock rate of 18 MHz and requires a minimum of 18 clocks at that frequency to do a 12-bit conversion.

The block functionality is augmented for the user by adding a reference buffer to it (trimmable to  $\pm 1\%$ ) and by providing the choice (for the PSoC 4200 case) of three internal voltage references:  $V_{DD}$ ,  $V_{DD}/2$ , and  $V_{REF}$  (nominally 1.024 V) as well as an external reference through a GPIO pin. The Sample-and-Hold (S/H) aperture is programmable allowing the gain bandwidth requirements of the amplifier driving the SAR inputs, which determine its settling time, to be relaxed if required. System performance will be 65 dB for true 12-bit precision providing appropriate references are used and system noise levels permit. To improve performance in noisy conditions, it is possible to provide an external bypass (through a fixed pin location) for the internal reference amplifier.

The SAR is connected to a fixed set of pins through an 8-input sequencer. The sequencer cycles through selected channels autonomously (sequencer scan) and does so with zero switching overhead (that is, aggregate sampling bandwidth is equal to 1 Msp/s whether it is for a single channel or distributed over several channels). The sequencer switching is effected through a state machine or through firmware driven switching. A feature provided by the sequencer is buffering of each channel to reduce CPU interrupt service requirements. To accommodate signals with varying source impedance and frequency, it is possible to have different sample times programmable for each channel. Also, signal range specification through a pair of range registers (low and high range values) is implemented with a corresponding out-of-range interrupt if the digitized value exceeds the programmed range; this allows fast detection of out-of-range values without the necessity of having to wait for a sequencer scan to be completed and the CPU to read the values and check for out-of-range values in software.

The SAR is able to digitize the output of the on-board temperature sensor for calibration and other temperature-dependent functions. The SAR is not available in Deep Sleep and Hibernate modes as it requires a high-speed clock (up to 18 MHz). The SAR operating range is 1.71 to 5.5 V.

**Figure 3. SAR ADC System Diagram**

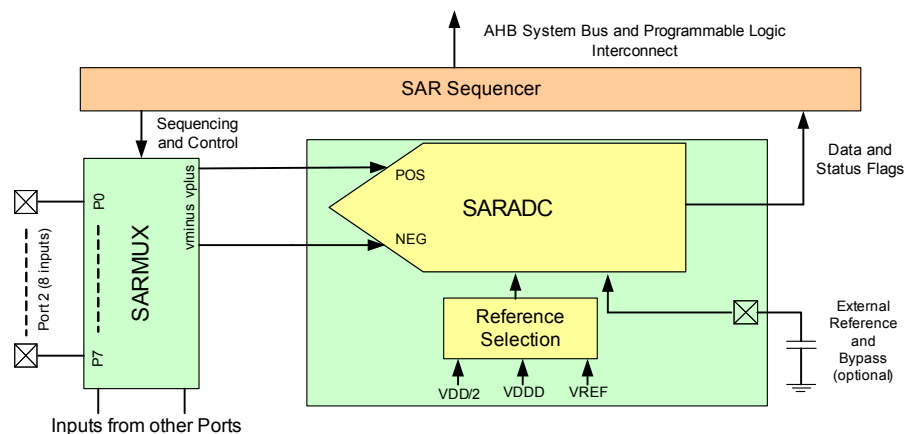

*Two Opamps (CTBm Block)*

The PSoC 4200 has two opamps with Comparator modes which allow most common analog functions to be performed on-chip eliminating external components; PGAs, Voltage Buffers, Filters, Trans-Impedance Amplifiers, and other functions can be realized with external passives saving power, cost, and space. The on-chip opamps are designed with enough bandwidth to drive the Sample-and-Hold circuit of the ADC without requiring external buffering.

*Temperature Sensor*

The PSoC 4200 has one on-chip temperature sensor This consists of a diode, which is biased by a current source that can be disabled to save power. The temperature sensor is connected to the ADC, which digitizes the reading and produces a temperature value using Cypress supplied software that includes calibration and linearization.

*Low-power Comparators*

The PSoC 4200 has a pair of low-power comparators, which can also operate in the Deep Sleep and Hibernate modes. This allows the analog system blocks to be disabled while retaining the ability to monitor external voltage levels during low-power modes. The comparator outputs are normally synchronized to avoid metastability unless operating in an asynchronous power mode (Hibernate) where the system wake-up circuit is activated by a comparator switch event.

**Programmable Digital**

*Universal Digital Blocks (UDBs) and Port Interfaces*

The PSoC 4200 has four UDBs; the UDB array also provides a switched Digital System Interconnect (DSI) fabric that allows signals from peripherals and ports to be routed to and through the UDBs for communication and control. The UDB array is shown in the following figure.

**Figure 4. UDB Array**

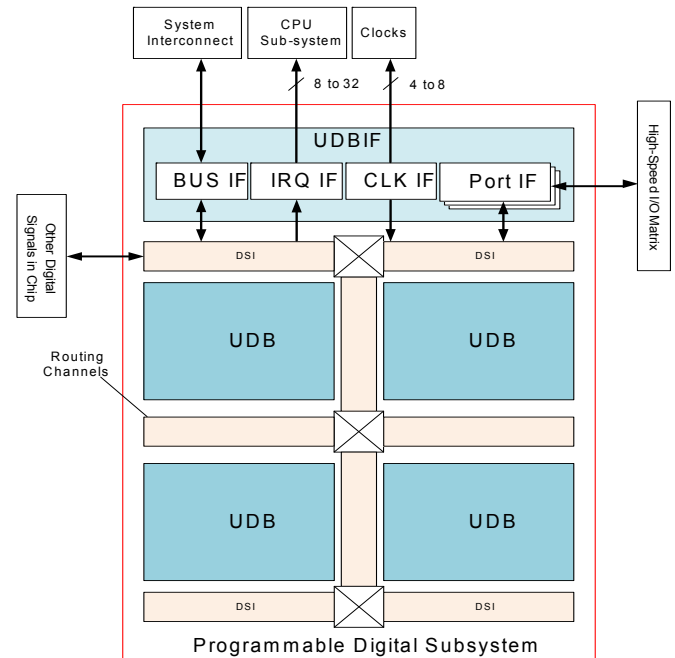

UDBs can be clocked from a clock divider block, from a port interface (required for peripherals such as SPI), and from the DSI network directly or after synchronization.

A port interface is defined, which acts as a register that can be clocked with the same source as the PLDs inside the UDB array. This allows faster operation because the inputs and outputs can be registered at the port interface close to the I/O pins and at the edge of the array. The port interface registers can be clocked by one of the I/Os from the same port. This allows interfaces such as SPI to operate at higher clock speeds by eliminating the delay for the port input to be routed over DSI and used to register other inputs (see Figure 5).

**Figure 5. Port Interface**

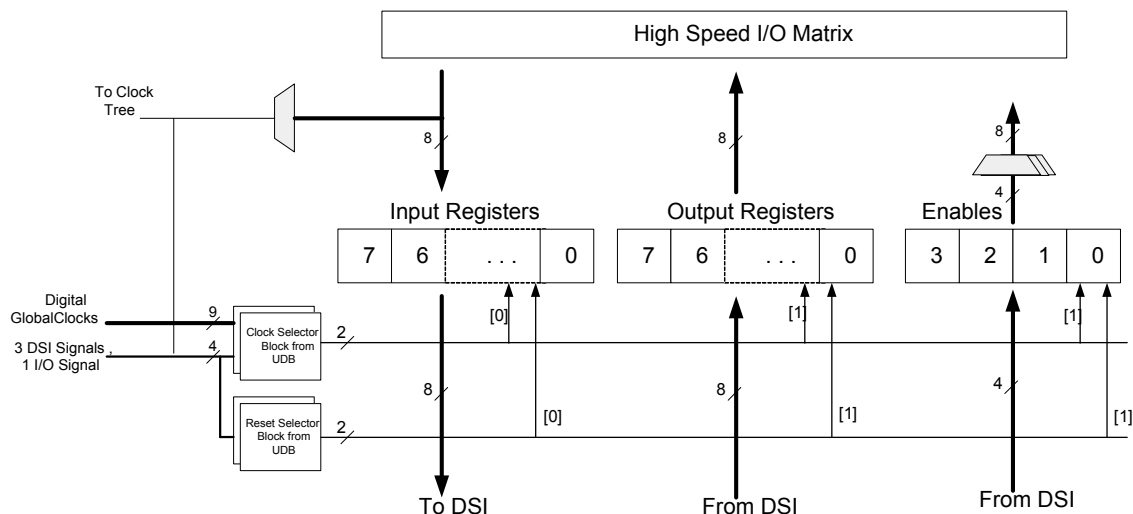

The UDBs can generate interrupts (one UDB at a time) to the interrupt controller. The UDBs retain the ability to connect to any pin on the chip through the DSI.

## Fixed Function Digital

### Timer/Counter/PWM Block

The Timer/Counter/PWM block consists of four 16-bit counters with user-programmable period length. There is a Capture register to record the count value at the time of an event (which may be an I/O event), a period register which is used to either stop or auto-reload the counter when its count is equal to the period register, and compare registers to generate compare value signals which are used as PWM duty cycle outputs. The block also provides true and complementary outputs with programmable offset between them to allow use as deadband programmable complementary PWM outputs. It also has a Kill input to force outputs to a predetermined state; for example, this is used in motor drive systems when an overcurrent state is indicated and the PWMs driving the FETs need to be shut off immediately with no time for software intervention.

### Serial Communication Blocks (SCB)

The PSoC 4200 has two SCBs, which can each implement an I<sup>2</sup>C, UART, or SPI interface.

**I<sup>2</sup>C Mode:** The hardware I<sup>2</sup>C block implements a full multi-master and slave interface (it is capable of multimaster arbitration). This block is capable of operating at speeds of up to 1 Mbps (Fast Mode Plus) and has flexible buffering options to reduce interrupt overhead and latency for the CPU. It also supports EzI<sup>2</sup>C that creates a mailbox address range in the memory of the PSoC 4200 and effectively reduces I<sup>2</sup>C communication to reading from and writing to an array in memory. In addition, the block supports an 8-deep FIFO for receive and transmit which, by increasing the time given for the CPU to read data, greatly reduces the need for clock stretching caused by the CPU not having read data on time. The FIFO mode is available in all channels and is very useful in the absence of DMA.

The I<sup>2</sup>C peripheral is compatible with the I<sup>2</sup>C Standard-mode, Fast-mode, and Fast-mode Plus devices as defined in the NXP I<sup>2</sup>C-bus specification and user manual (UM10204). The I<sup>2</sup>C bus I/O is implemented with GPIO in open-drain modes.

The PSoC 4200 is not completely compliant with the I<sup>2</sup>C spec in the following respects:

- GPIO cells are not overvoltage tolerant and, therefore, cannot be hot-swapped or powered up independently of the rest of the I<sup>2</sup>C system.
- Fast-mode Plus has an I<sub>OL</sub> specification of 20 mA at a V<sub>OL</sub> of 0.4 V. The GPIO cells can sink a maximum of 8 mA I<sub>OL</sub> with a V<sub>OL</sub> maximum of 0.6 V.
- Fast-mode and Fast-mode Plus specify minimum Fall times, which are not met with the GPIO cell; Slow strong mode can help meet this spec depending on the Bus Load.

- When the SCB is an I<sup>2</sup>C Master, it interposes an IDLE state between NACK and Repeated Start; the I<sup>2</sup>C spec defines Bus free as following a Stop condition so other Active Masters do not intervene but a Master that has just become activated may start an Arbitration cycle.

- When the SCB is in I<sup>2</sup>C Slave mode, and Address Match on External Clock is enabled (EC\_AM = 1) along with operation in the internally clocked mode (EC\_OP = 0), then its I<sup>2</sup>C address must be even.

**UART Mode:** This is a full-feature UART operating at up to 1 Mbps. It supports automotive single-wire interface (LIN), infrared interface (IrDA), and SmartCard (ISO7816) protocols, all of which are minor variants of the basic UART protocol. In addition, it supports the 9-bit multiprocessor mode that allows addressing of peripherals connected over common RX and TX lines. Common UART functions such as parity error, break detect, and frame error are supported. An 8-deep FIFO allows much greater CPU service latencies to be tolerated. Note that hardware handshaking is not supported. This is not commonly used and can be implemented with a UDB-based UART in the system, if required.

**SPI Mode:** The SPI mode supports full Motorola SPI, TI SSP (essentially adds a start pulse used to synchronize SPI Coders), and National Microwire (half-duplex form of SPI). The SPI block can use the FIFO and also supports an EzSPI mode in which data interchange is reduced to reading and writing an array in memory.

## GPIO

The PSoC 4200 has 36 GPIOs. The GPIO block implements the following:

- Eight drive strength modes:
  - Analog input mode (input and output buffers disabled)
  - Input only
  - Weak pull-up with strong pull-down
  - Strong pull-up with weak pull-down
  - Open drain with strong pull-down
  - Open drain with strong pull-up
  - Strong pull-up with strong pull-down
  - Weak pull-up with weak pull-down
- Input threshold select (CMOS or LVTTTL).
- Individual control of input and output buffer enabling/disabling in addition to the drive strength modes.
- Hold mode for latching previous state (used for retaining I/O state in Deep Sleep mode and Hibernate modes).
- Selectable slew rates for dV/dt related noise control to improve EMI.

The pins are organized in logical entities called ports, which are 8-bit in width. During power-on and reset, the blocks are forced to the disable state so as not to crowbar any inputs and/or cause excess turn-on current. A multiplexing network known as a high-speed I/O matrix is used to multiplex between various signals that may connect to an I/O pin. Pin locations for fixed-function peripherals are also fixed to reduce internal multiplexing complexity (these signals do not go through the DSI network). DSI signals are not affected by this and any pin may be routed to any UDB through the DSI network.

Data output and pin state registers store, respectively, the values to be driven on the pins and the states of the pins themselves.

Every I/O pin can generate an interrupt if so enabled and each I/O port has an interrupt request (IRQ) and interrupt service routine (ISR) vector associated with it (5 for PSoC 4200 since it has 4.5 ports).

## Special Function Peripherals

### *LCD Segment Drive*

The PSoC 4200 has an LCD controller which can drive up to four commons and up to 32 segments. It uses full digital methods to drive the LCD segments requiring no generation of internal LCD voltages. The two methods used are referred to as digital correlation and PWM.

Digital correlation pertains to modulating the frequency and levels of the common and segment signals to generate the highest RMS voltage across a segment to light it up or to keep the RMS signal zero. This method is good for STN displays but may result in reduced contrast with TN (cheaper) displays.

PWM pertains to driving the panel with PWM signals to effectively use the capacitance of the panel to provide the integration of the modulated pulse-width to generate the desired LCD voltage. This method results in higher power consumption but can result in better results when driving TN displays. LCD operation is supported during Deep Sleep refreshing a small display buffer (4 bits; 1 32-bit register per port).

### *CapSense*

CapSense is supported on all pins in the PSoC 4200 through a CapSense Sigma-Delta (CSD) block that can be connected to any pin through an analog mux bus that any GPIO pin can be connected to via an Analog switch. CapSense function can thus be provided on any pin or group of pins in a system under software control. A component is provided for the CapSense block to make it easy for the user.

Shield voltage can be driven on another Mux Bus to provide water tolerance capability. Water tolerance is provided by driving the shield electrode in phase with the sense electrode to keep the shield capacitance from attenuating the sensed input.

The CapSense block has two IDACs which can be used for general purposes if CapSense is not being used. (both IDACs are available in that case) or if CapSense is used without water tolerance (one IDAC is available).



## Pinouts

The following is the pin-list for the PSoC 4200. Port 2 comprises of the high-speed Analog inputs for the SAR Mux. P1.7 is the optional external input and bypass for the SAR reference. Ports 3 and 4 contain the Digital Communication channels. All pins support CSD CapSense and Analog Mux Bus connections.

Pins		44-TQFP		40-QFN		28-SSOP		Alternate Functions for Pins					Pin Description
Name	Type	Pin	Name	Pin	Name	Pin	Name	Analog	Alt 1	Alt 2	Alt 3	Alt 4	
VSSD	Power	1(DN)	VSS	DN	–	DN	–	–	–	–	–	–	Digital Ground
P2.0	GPIO	2	P2.0	1	P2.0	–	–	sarmux.0	–	–	–	–	Port 2 Pin 0: gpio, lcd, csd, sarmux
P2.1	GPIO	3	P2.1	2	P2.1	–	–	sarmux.1	–	–	–	–	Port 2 Pin 1: gpio, lcd, csd, sarmux
P2.2	GPIO	4	P2.2	3	P2.2	5	P2.2	sarmux.2	–	–	–	–	Port 2 Pin 2: gpio, lcd, csd, sarmux
P2.3	GPIO	5	P2.3	4	P2.3	6	P2.3	sarmux.3	–	–	–	–	Port 2 Pin 3: gpio, lcd, csd, sarmux
P2.4	GPIO	6	P2.4	5	P2.4	7	P2.4	sarmux.4	tcpwm0_p[1]	–	–	–	Port 2 Pin 4: gpio, lcd, csd, sarmux, pwm
P2.5	GPIO	7	P2.5	6	P2.5	8	P2.5	sarmux.5	tcpwm0_n[1]	–	–	–	Port 2 Pin 5: gpio, lcd, csd, sarmux, pwm
P2.6	GPIO	8	P2.6	7	P2.6	9	P2.6	sarmux.6	tcpwm1_p[1]	–	–	–	Port 2 Pin 6: gpio, lcd, csd, sarmux, pwm
P2.7	GPIO	9	P2.7	8	P2.7	10	P2.7	sarmux.7	tcpwm1_n[1]	–	–	–	Port 2 Pin 7: gpio, lcd, csd, sarmux, pwm
–	–	10(DN)	VSS	9(DN)	VSS	–	–	–	–	–	–	–	Package pin to lead frame paddle downbond
P3.0	GPIO	11	P3.0	10	P3.0	11	P3.0	–	tcpwm0_p[0]	scb1_uart_rx[0]	scb1_i2c_scl[0]	scb1_spi_mosi[0]	Port 3 Pin 0: gpio, lcd, csd, pwm, scb1
P3.1	GPIO	12	P3.1	11	P3.1	12	P3.1	–	tcpwm0_n[0]	scb1_uart_tx[0]	scb1_i2c_sda[0]	scb1_spi_miso[0]	Port 3 Pin 1: gpio, lcd, csd, pwm, scb1
P3.2	GPIO	13	P3.2	12	P3.2	13	P3.2	–	tcpwm1_p[0]	–	swd_io	scb1_spi_clk[0]	Port 3 Pin 2: gpio, lcd, csd, pwm, scb1, swd
P3.3	GPIO	14	P3.3	13	P3.3	14	P3.3	–	tcpwm1_n[0]	–	swd_clk	scb1_spi_ssel_0[0]	Port 3 Pin 3: gpio, lcd, csd, pwm, scb1, swd
P3.4	GPIO	15	P3.4	14	P3.4	–	–	–	tcpwm2_p[0]	–	–	scb1_spi_ssel_1	Port 3 Pin 4: gpio, lcd, csd, pwm, scb1
P3.5	GPIO	16	P3.5	15	P3.5	–	–	–	tcpwm2_n[0]	–	–	scb1_spi_ssel_2	Port 3 Pin 5: gpio, lcd, csd, pwm, scb1
P3.6	GPIO	17	P3.6	16	P3.6	–	–	–	tcpwm3_p[0]	–	–	scb1_spi_ssel_3	Port 3 Pin 6: gpio, lcd, csd, pwm, scb1
P3.7	GPIO	18	P3.7	17	P3.7	–	–	–	tcpwm3_n[0]	–	–	–	Port 3 Pin 7: gpio, lcd, csd, pwm
VDDD	Power	19	VDDD	–	–	–	–	–	–	–	–	–	Digital Supply, 1.8 - 5.5 V
P4.0	GPIO	20	P4.0	18	P4.0	15	P4.0	–	–	scb0_uart_rx	scb0_i2c_scl	scb0_spi_mosi	Port 4 Pin 0: gpio, lcd, csd, scb0
P4.1	GPIO	21	P4.1	19	P4.1	16	P4.1	–	–	scb0_uart_tx	scb0_i2c_sda	scb0_spi_miso	Port 4 Pin 1: gpio, lcd, csd, scb0
P4.2	GPIO	22	P4.2	20	P4.2	17	P4.2	csd_c_mod	–	–	–	scb0_spi_clk	Port 4 Pin 2: gpio, lcd, csd, scb0
P4.3	GPIO	23	P4.3	21	P4.3	18	P4.3	csd_c_sh_t ank	–	–	–	scb0_spi_ssel_0	Port 4 Pin 3: gpio, lcd, csd, scb0
P0.0	GPIO	24	P0.0	22	P0.0	19	P0.0	comp1_inp	–	–	–	scb0_spi_ssel_1	Port 0 Pin 0: gpio, lcd, csd, scb0, comp
P0.1	GPIO	25	P0.1	23	P0.1	20	P0.1	comp1_inn	–	–	–	scb0_spi_ssel_2	Port 0 Pin 1: gpio, lcd, csd, scb0, comp
P0.2	GPIO	26	P0.2	24	P0.2	21	P0.2	comp2_inp	–	–	–	scb0_spi_ssel_3	Port 0 Pin 2: gpio, lcd, csd, scb0, comp
P0.3	GPIO	27	P0.3	25	P0.3	22	P0.3	comp2_inn	–	–	–	–	Port 0 Pin 3: gpio, lcd, csd, comp
P0.4	GPIO	28	P0.4	26	P0.4	–	–	–	–	scb1_uart_rx[1]	scb1_i2c_scl[1]	scb1_spi_mosi[1]	Port 0 Pin 4: gpio, lcd, csd, scb1
P0.5	GPIO	29	P0.5	27	P0.5	–	–	–	–	scb1_uart_tx[1]	scb1_i2c_sda[1]	scb1_spi_miso[1]	Port 0 Pin 5: gpio, lcd, csd, scb1
P0.6	GPIO	30	P0.6	28	P0.6	23	P0.6	–	ext_clk	–	–	scb1_spi_clk[1]	Port 0 Pin 6: gpio, lcd, csd, scb1, ext_clk
P0.7	GPIO	31	P0.7	29	P0.7	24	P0.7	–	–	–	wakeup	scb1_spi_ssel_0[1]	Port 0 Pin 7: gpio, lcd, csd, scb1, wakeup

Pins		44-TQFP		40-QFN		28-SSOP		Alternate Functions for Pins					Pin Description
Name	Type	Pin	Name	Pin	Name	Pin	Name	Analog	Alt 1	Alt 2	Alt 3	Alt 4	
XRES	XRES	32	XRES	30	XRES	25	XRES	–	–	–	–	–	Chip reset, active low
VCCD	Power	33	VCCD	31	VCCD	26	VCCD	–	–	–	–	–	Regulated supply, connect to 1 $\mu$ F cap or 1.8 V
VDDD	Power	34	VDDD	32	VDDD	27	VDD	–	–	–	–	–	Digital Supply, 1.8 - 5.5 V
VDDA	Power	35	VDDA	33	VDDA	27	VDD	–	–	–	–	–	Analog Supply, 1.8 - 5.5 V, equal to VDDD
VSSA	Power	36	VSSA	34	VSSA	28(D N)	VSS	–	–	–	–	–	Analog Ground
P1.0	GPIO	37	P1.0	35	P1.0	1	P1.0	ctb. oa0.inp	tcpwm2_p[1]	–	–	–	Port 1 Pin 0: gpio, lcd, csd, ctb, pwm
P1.1	GPIO	38	P1.1	36	P1.1	2	P1.1	ctb. oa0.inm	tcpwm2_n[1]	–	–	–	Port 1 Pin 1: gpio, lcd, csd, ctb, pwm
P1.2	GPIO	39	P1.2	37	P1.2	3	P1.2	ctb. oa0.out	tcpwm3_p[1]	–	–	–	Port 1 Pin 2: gpio, lcd, csd, ctb, pwm
P1.3	GPIO	40	P1.3	38	P1.3	–	–	ctb. oa1.out	tcpwm3_n[1]	–	–	–	Port 1 Pin 3: gpio, lcd, csd, ctb, pwm
P1.4	GPIO	41	P1.4	39	P1.4	–	–	ctb. oa1.inm	–	–	–	–	Port 1 Pin 4: gpio, lcd, csd, ctb
P1.5	GPIO	42	P1.5	–	–	–	–	ctb. oa1.inp	–	–	–	–	Port 1 Pin 5: gpio, lcd, csd, ctb
P1.6	GPIO	43	P1.6	–	–	–	–	ctb. oa0.inp_alt	–	–	–	–	Port 1 Pin 6: gpio, lcd, csd
P1.7	GPIO	44	P1.7	40	P1.7	4	P1.7	ctb. oa1.inp_alt ext_vref	–	–	–	–	Port 1 Pin 7: gpio, lcd, csd, ext_ref

**Descriptions of the Pin functions are as follows:**

**VDDD:** Power supply for both analog and digital sections (where there is no  $V_{DDA}$  pin).

**VDDA:** Analog  $V_{DD}$  pin where package pins allow; shorted to  $V_{DDD}$  otherwise.

**VSSA:** Analog ground pin where package pins allow; shorted to VSS otherwise

**VSS:** Ground pin.

**VCCD:** Regulated Digital supply (1.8 V  $\pm$ 5%).

Port Pins can all be used as LCD Commons, LCD Segment drivers, or CSD sense and shield pins can be connected to AMUXBUS A or B or can all be used as GPIO pins that can be driven by firmware or DSI signals.

The following packages are supported: 44-pin TQFP, 40-pin QFN, and 28-pin SSOP.

**Figure 6. 44-pin TQFP Part Pinout**

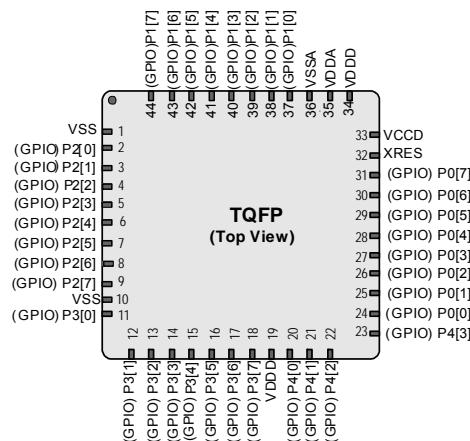

Figure 7. 40-Pin QFN Pinout

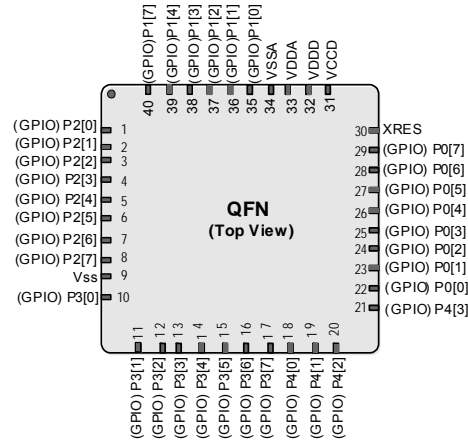
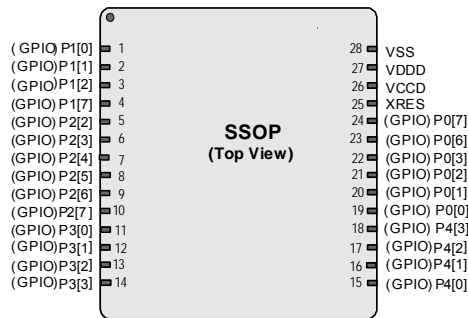

Figure 8. 28-Pin SSOP Pinout



## Power

The following power system diagram shows the minimum set of power supply pins as implemented for the PSoC 4200. The system has one regulator in Active mode for the digital circuitry. There is no analog regulator; the analog circuits run directly from the V<sub>DDA</sub> input. There are separate regulators for the Deep Sleep and Hibernate (lowered power supply and retention) modes. There is a separate low-noise regulator for the bandgap. The supply voltage range is 1.71 to 5.5 V with all functions and circuits operating over that range.

The PSoC 4200 family allows two distinct modes of power supply operation: Unregulated External Supply, and Regulated External Supply modes.

### Unregulated External Supply

In this mode, the PSoC 4200 is powered by an External Power Supply that can be anywhere in the range of 1.8 to 5.5V. This range is also designed for battery-powered operation, for instance, the chip can be powered from a battery system that starts at 3.5V and works down to 1.8V. In this mode, the internal regulator of the PSoC 4200 supplies the internal logic and the VCCD output of the PSoC 4200 must be bypassed to ground via an external Capacitor (in the range of 1 to 1.6  $\mu\text{F}$ ; X5R ceramic or better).

VDDA and VDDD must be shorted together; the grounds, VSSA and VSS must also be shorted together. Bypass capacitors must be used from VDDD to ground, typical practice for systems in this frequency range is to use a capacitor in the 1  $\mu\text{F}$  range in parallel with a smaller capacitor (0.1  $\mu\text{F}$  for example). Note that these are simply rules of thumb and that, for critical applications, the PCB layout, lead inductance, and the Bypass capacitor parasitic should be simulated to design and obtain optimal bypassing.

An example of a bypass scheme for the 44 TQFP package follows.

**Figure 9. 44-TQFP Package Example**

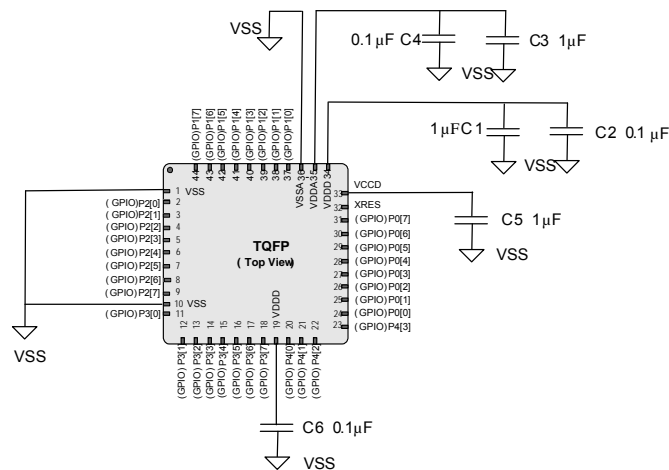

Power Supply	Bypass Capacitors
VDDD–VSS	0.1 $\mu\text{F}$ ceramic at each pin (C2, C6) plus bulk capacitor 1 to 10 $\mu\text{F}$ (C1).
VDDA–VSSA	0.1 $\mu\text{F}$ ceramic at pin (C4). Additional 1 $\mu\text{F}$ to 10 $\mu\text{F}$ (C3) bulk capacitor
VCCD–VSS	1 $\mu\text{F}$ ceramic capacitor at the VCCD pin (C5)
VREF–VSSA (optional)	The internal bandgap may be bypassed with a 1 $\mu\text{F}$ to 10 $\mu\text{F}$ capacitor.

**Figure 10. 40-pin QFN Example**

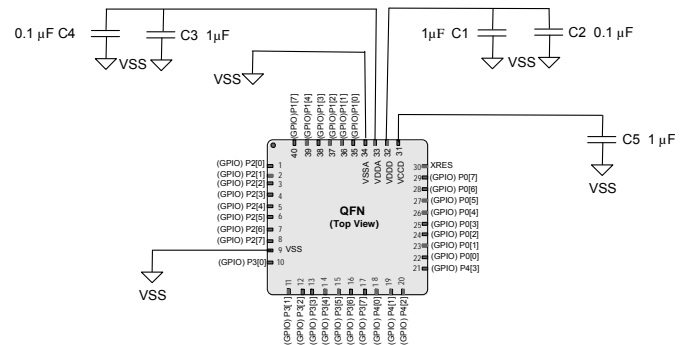

**Figure 11. 28-SSOP Example**

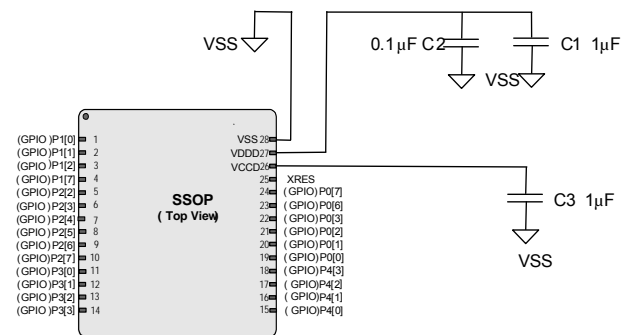

### Regulated External Supply

In this mode, the PSoC 4200 is powered by an external power supply that must be within the range of 1.71 to 1.89 V (1.8  $\pm 5\%$ ); note that this range needs to include power supply ripple too. In this mode, VCCD, VDDA, and VDDD pins are all shorted together and bypassed. The internal regulator is disabled in firmware.

## Development Support

The PSoC 4200 family has a rich set of documentation, development tools, and online resources to assist you during your development process. Visit [www.cypress.com/go/psoc4](http://www.cypress.com/go/psoc4) to find out more.

### Documentation

A suite of documentation supports the PSoC 4200 family to ensure that you can find answers to your questions quickly. This section contains a list of some of the key documents.

**Software User Guide:** A step-by-step guide for using PSoC Creator. The software user guide shows you how the PSoC Creator build process works in detail, how to use source control with PSoC Creator, and much more.

**Component Datasheets:** The flexibility of PSoC allows the creation of new peripherals (components) long after the device has gone into production. Component data sheets provide all of the information needed to select and use a particular component, including a functional description, API documentation, example code, and AC/DC specifications.

**Application Notes:** PSoC application notes discuss a particular application of PSoC in depth; examples include brushless DC

motor control and on-chip filtering. Application notes often include example projects in addition to the application note document.

**Technical Reference Manual:** The Technical Reference Manual (TRM) contains all the technical detail you need to use a PSoC device, including a complete description of all PSoC registers. The TRM is available in the Documentation section at [www.cypress.com/psoc4](http://www.cypress.com/psoc4).

### Online

In addition to print documentation, the Cypress PSoC forums connect you with fellow PSoC users and experts in PSoC from around the world, 24 hours a day, 7 days a week.

### Tools

With industry standard cores, programming, and debugging interfaces, the PSoC 4200 family is part of a development tool ecosystem. Visit us at [www.cypress.com/go/psoccreator](http://www.cypress.com/go/psoccreator) for the latest information on the revolutionary, easy to use PSoC Creator IDE, supported third party compilers, programmers, debuggers, and development kits.

## Electrical Specifications

### Absolute Maximum Ratings

Table 1. Absolute Maximum Ratings<sup>[1]</sup>

Spec ID#	Parameter	Description	Min	Typ	Max	Units	Details/Conditions
SID1	V <sub>DDD_ABS</sub>	Digital supply relative to V <sub>SSD</sub>	-0.5	-	6	V	Absolute max
SID2	V <sub>CCD_ABS</sub>	Direct digital core voltage input relative to V <sub>SSD</sub>	-0.5	-	1.95	V	Absolute max
SID3	V <sub>GPIO_ABS</sub>	GPIO voltage	-0.5	-	V <sub>DD</sub> +0.5	V	Absolute max
SID4	I <sub>GPIO_ABS</sub>	Maximum current per GPIO	-25	-	25	mA	Absolute max
SID5	I <sub>GPIO_injection</sub>	GPIO injection current, Max for V <sub>IH</sub> > V <sub>DDD</sub> , and Min for V <sub>IL</sub> < V <sub>SS</sub>	-0.5	-	0.5	mA	Absolute max, current injected per pin
BID44	ESD_HBM	Electrostatic discharge human body model	2200	-	-	V	
BID45	ESD_CDM	Electrostatic discharge charged device model	500	-	-	V	
BID46	LU	Pin current for Latch-up	-200	-	200	mA	

### Device Level Specifications

All specifications are valid for -40 °C ≤ TA ≤ 85 °C and TJ ≤ 100 °C, except where noted. Specifications are valid for 1.71 V to 5.5 V, except where noted.

Table 2. DC Specifications

Spec ID#	Parameter	Description	Min	Typ	Max	Units	Details/Conditions
SID53	V <sub>DDD</sub>	Power supply input voltage	1.8	-	5.5	V	With regulator enabled
SID255	V <sub>DDD</sub>	Power supply input voltage unregulated	1.71	1.8	1.89	V	Internally unregulated supply
SID54	V <sub>CCD</sub>	Output voltage (for core logic)	-	1.8	-	V	
SID55	C <sub>EFC</sub>	External regulator voltage bypass	1	1.3	1.6	μF	X5R ceramic or better
SID56	C <sub>EXC</sub>	Power supply decoupling capacitor	-	1	-	μF	X5R ceramic or better

**Active Mode, V<sub>DDD</sub> = 1.71 to 5.5 V. Typical values measured at V<sub>DD</sub> = 3.3 V.**

SID9	I <sub>DD5</sub>	Execute from Flash; CPU at 6 MHz	-	-	2.8	mA	
SID10	I <sub>DD6</sub>	Execute from Flash; CPU at 6 MHz	-	2.2	-	mA	T = 25 °C
SID12	I <sub>DD8</sub>	Execute from Flash; CPU at 12 MHz	-	-	4.2	mA	
SID13	I <sub>DD9</sub>	Execute from Flash; CPU at 12 MHz	-	3.7	-	mA	T = 25 °C
SID16	I <sub>DD11</sub>	Execute from Flash; CPU at 24 MHz	-	6.7	-	mA	T = 25 °C
SID17	I <sub>DD12</sub>	Execute from Flash; CPU at 24 MHz	-	-	7.2	mA	
SID19	I <sub>DD14</sub>	Execute from Flash; CPU at 48 MHz	-	12.8	-	mA	T = 25 °C
SID20	I <sub>DD15</sub>	Execute from Flash; CPU at 48 MHz	-	-	13.8	mA	

#### Note

- Usage above the absolute maximum conditions listed in Table 1 may cause permanent damage to the device. Exposure to absolute maximum conditions for extended periods of time may affect device reliability. The maximum storage temperature is 150 °C in compliance with JEDEC Standard JESD22-A103, High Temperature Storage Life. When used below absolute maximum conditions but above normal operating conditions, the device may not operate to specification.

**Table 2. DC Specifications (continued)**

Spec ID#	Parameter	Description	Min	Typ	Max	Units	Details/ Conditions
<b>Sleep Mode, V<sub>DD</sub> = 1.7 to 5.5 V</b>							
SID25	I <sub>DD20</sub>	I <sup>2</sup> C wakeup, WDT, and comparators on. 6 MHz	–	1.3	1.8	mA	
SID25A	I <sub>DD20A</sub>	I <sup>2</sup> C wakeup, WDT, and comparators on. 12 MHz	–	1.7	2.2	mA	
<b>Deep Sleep Mode, V<sub>DD</sub> = 1.8 to 3.6 V (Regulator on)</b>							
SID31	I <sub>DD26</sub>	I <sup>2</sup> C wakeup and WDT on	–	1.3	–	μA	T = 25 °C, 3.6 V
SID32	I <sub>DD27</sub>	I <sup>2</sup> C wakeup and WDT on	–	–	50	μA	T = 85 °C
<b>Deep Sleep Mode, V<sub>DD</sub> = 3.6 to 5.5 V</b>							
SID34	I <sub>DD29</sub>	I <sup>2</sup> C wakeup and WDT on	–	15	–	μA	T = 25 °C, 5.5 V
<b>Deep Sleep Mode, V<sub>DD</sub> = 1.71 to 1.89 V (Regulator bypassed)</b>							
SID37	I <sub>DD32</sub>	I <sup>2</sup> C wakeup and WDT on	–	1.7	–	μA	T = 25 °C
SID38	I <sub>DD33</sub>	I <sup>2</sup> C wakeup and WDT on	–	–	440	μA	T = 85 °C
<b>Hibernate Mode, V<sub>DD</sub> = 1.8 to 3.6 V (Regulator on; Guaranteed by Characterization)</b>							
SID40	I <sub>DD35</sub>	GPIO and reset active	–	150	–	nA	T = 25 °C, 3.6 V
SID41	I <sub>DD36</sub>	GPIO and reset active	–	–	1	μA	T = 85 °C
<b>Hibernate Mode, V<sub>DD</sub> = 3.6 to 5.5 V (Guaranteed by Characterization)</b>							
SID43	I <sub>DD38</sub>	GPIO and reset active	–	150	–	nA	T = 25 °C, 5.5 V
<b>Hibernate Mode, V<sub>DD</sub> = 1.71 to 1.89 V (Regulator bypassed; Guaranteed by Characterization)</b>							
SID46	I <sub>DD41</sub>	GPIO and reset active	–	150	–	nA	T = 25 °C
SID47	I <sub>DD42</sub>	GPIO and reset active	–	–	1	μA	T = 85 °C
<b>Stop Mode (Guaranteed by Characterization)</b>							
SID304	I <sub>DD43A</sub>	Stop Mode current; V <sub>DD</sub> = 3.6 V	–	20	80	nA	
<b>XRES Current</b>							
SID307	I <sub>DD_XR</sub>	Supply current while XRES asserted	–	2	5	mA	

**Table 3. AC Specifications**

Spec ID#	Parameter	Description	Min	Typ	Max	Units	Details/ Conditions
SID48	F <sub>CPU</sub>	CPU frequency	DC	–	48	MHz	1.71 ≤ V <sub>DD</sub> ≤ 5.5
SID49	T <sub>SLEEP</sub>	Wakeup from sleep mode	–	0	–	μs	Guaranteed by characterization
SID50	T <sub>DEEPSLEEP</sub>	Wakeup from Deep Sleep mode	–	–	25	μs	24 MHz IMO. Guaranteed by characterization
SID51	T <sub>HIBERNATE</sub>	Wakeup from Hibernate and Stop modes	–	–	2	ms	Guaranteed by characterization
SID52	T <sub>RESETWIDTH</sub>	External reset pulse width	1	–	–	μs	Guaranteed by characterization

GPIO

Table 4. GPIO DC Specifications

Spec ID#	Parameter	Description	Min	Typ	Max	Units	Details/ Conditions
SID57	$V_{IH}^{[2]}$	Input voltage high threshold	$0.7 \times V_{DD3}$	–	–	V	CMOS Input
SID58	$V_{IL}$	Input voltage low threshold	–	–	$0.3 \times V_{DD3}$	V	CMOS Input
SID241	$V_{IH}^{[2]}$	LVTTL input, $V_{DD3} < 2.7$ V	$0.7 \times V_{DD3}$	–	–	V	
SID242	$V_{IL}$	LVTTL input, $V_{DD3} < 2.7$ V	–	–	$0.3 \times V_{DD3}$	V	
SID243	$V_{IH}^{[2]}$	LVTTL input, $V_{DD3} \geq 2.7$ V	2.0	–	–	V	
SID244	$V_{IL}$	LVTTL input, $V_{DD3} \geq 2.7$ V	–	–	0.8	V	
SID59	$V_{OH}$	Output voltage high level	$V_{DD3} - 0.6$	–	–	V	$I_{OH} = 4$ mA at $3 V V_{DD3}$
SID60	$V_{OH}$	Output voltage high level	$V_{DD3} - 0.5$	–	–	V	$I_{OH} = 1$ mA at $1.8 V V_{DD3}$
SID61	$V_{OL}$	Output voltage low level	–	–	0.6	V	$I_{OL} = 4$ mA at $1.8 V V_{DD3}$
SID62	$V_{OL}$	Output voltage low level	–	–	0.6	V	$I_{OL} = 8$ mA at $3 V V_{DD3}$
SID62A	$V_{OL}$	Output voltage low level	–	–	0.4	V	$I_{OL} = 3$ mA at $3 V V_{DD3}$
SID63	$R_{PULLUP}$	Pull-up resistor	3.5	5.6	8.5	k $\Omega$	
SID64	$R_{PULLDOWN}$	Pull-down resistor	3.5	5.6	8.5	k $\Omega$	
SID65	$I_{IL}$	Input leakage current (absolute value)	–	–	2	nA	$25^{\circ}\text{C}$ , $V_{DD3} = 3.0$ V
SID65A	$I_{IL\_CTBM}$	Input leakage current (absolute value) for CTBM pins	–	–	4	nA	
SID66	$C_{IN}$	Input capacitance	–	–	7	pF	
SID67	$V_{HYSTTL}$	Input hysteresis LVTTL	25	40	–	mV	$V_{DD3} \geq 2.7$ V. Guaranteed by characterization
SID68	$V_{HYSCMOS}$	Input hysteresis CMOS	$0.05 \times V_{DD3}$	–	–	mV	Guaranteed by characterization
SID69	$I_{DIODE}$	Current through protection diode to $V_{DD}/V_{SS}$	–	–	100	$\mu\text{A}$	Guaranteed by characterization
SID69A	$I_{TOT\_GPIO}$	Maximum Total Source or Sink Chip Current	–	–	200	mA	Guaranteed by characterization

Table 5. GPIO AC Specifications

(Guaranteed by Characterization)

Spec ID#	Parameter	Description	Min	Typ	Max	Units	Details/ Conditions
SID70	$T_{RISEF}$	Rise time in fast strong mode	2	–	12	ns	$3.3 V V_{DD3}$ , $C_{load} = 25$ pF
SID71	$T_{FALLF}$	Fall time in fast strong mode	2	–	12	ns	$3.3 V V_{DD3}$ , $C_{load} = 25$ pF

Note

2.  $V_{IH}$  must not exceed  $V_{DD3} + 0.2$  V.



**Table 5. GPIO AC Specifications**

(Guaranteed by Characterization) (continued)

Spec ID#	Parameter	Description	Min	Typ	Max	Units	Details/ Conditions
SID72	T <sub>RISES</sub>	Rise time in slow strong mode	10	–	60		3.3 V V <sub>DDD</sub> , Clod = 25 pF
SID73	T <sub>FALLS</sub>	Fall time in slow strong mode	10	–	60		3.3 V V <sub>DDD</sub> , Clod = 25 pF
SID74	F <sub>GPIOUT1</sub>	GPIO Fout; 3.3 V ≤ V <sub>DDD</sub> ≤ 5.5 V. Fast strong mode.	–	–	33	MHz	90/10%, 25 pF load, 60/40 duty cycle
SID75	F <sub>GPIOUT2</sub>	GPIO Fout; 1.7 V ≤ V <sub>DDD</sub> ≤ 3.3 V. Fast strong mode.	–	–	16.7	MHz	90/10%, 25 pF load, 60/40 duty cycle
SID76	F <sub>GPIOUT3</sub>	GPIO Fout; 3.3 V ≤ V <sub>DDD</sub> ≤ 5.5 V. Slow strong mode.	–	–	7	MHz	90/10%, 25 pF load, 60/40 duty cycle
SID245	F <sub>GPIOUT4</sub>	GPIO Fout; 1.7 V ≤ V <sub>DDD</sub> ≤ 3.3 V. Slow strong mode.	–	–	3.5	MHz	90/10%, 25 pF load, 60/40 duty cycle
SID246	F <sub>GPIOIN</sub>	GPIO input operating frequency; 1.71 V ≤ V <sub>DDD</sub> ≤ 5.5 V	–	–	48	MHz	90/10% V <sub>IO</sub>

XRES

**Table 6. XRES DC Specifications**

Spec ID#	Parameter	Description	Min	Typ	Max	Units	Details/ Conditions
SID77	V <sub>IH</sub>	Input voltage high threshold	0.7 × V <sub>DDD</sub>	–	–	V	CMOS Input
SID78	V <sub>IL</sub>	Input voltage low threshold	–	–	0.3 × V <sub>DDD</sub>	V	CMOS Input
SID79	R <sub>PULLUP</sub>	Pull-up resistor	3.5	5.6	8.5	kΩ	
SID80	C <sub>IN</sub>	Input capacitance	–	3	–	pF	
SID81	V <sub>HYSXRES</sub>	Input voltage hysteresis	–	100	–	mV	Guaranteed by characterization
SID82	I <sub>DIODE</sub>	Current through protection diode to V <sub>DDD</sub> /V <sub>SS</sub>	–	–	100	μA	Guaranteed by characterization

**Table 7. XRES AC Specifications**

Spec ID#	Parameter	Description	Min	Typ	Max	Units	Details/ Conditions
SID83	T <sub>RESETWIDTH</sub>	Reset pulse width	1	–	–	μs	Guaranteed by characterization

**Analog Peripherals**

Opamp

**Table 8. Opamp Specifications**

(Guaranteed by Characterization)

Spec ID#	Parameter	Description	Min	Typ	Max	Units	Details/ Conditions
	I <sub>DD</sub>	Opamp block current. No load.	–	–	–	–	
SID269	I <sub>DD_HI</sub>	Power = high	–	1000	1300	μA	
SID270	I <sub>DD_MED</sub>	Power = medium	–	320	500	μA	
SID271	I <sub>DD_LOW</sub>	Power = low	–	250	350	μA	
	GBW	Load = 20 pF, 0.1 mA. V <sub>D<sub>DDA</sub></sub> = 2.7 V	–	–	–	–	
SID272	GBW_HI	Power = high	6	–	–	MHz	
SID273	GBW_MED	Power = medium	4	–	–	MHz	
SID274	GBW_LO	Power = low	–	1	–	MHz	
	I <sub>OUT_MAX</sub>	V <sub>D<sub>DDA</sub></sub> ≥ 2.7 V, 500 mV from rail	–	–	–	–	
SID275	I <sub>OUT_MAX_HI</sub>	Power = high	10	–	–	mA	
SID276	I <sub>OUT_MAX_MID</sub>	Power = medium	10	–	–	mA	
SID277	I <sub>OUT_MAX_LO</sub>	Power = low	–	5	–	mA	
	I <sub>OUT</sub>	V <sub>D<sub>DDA</sub></sub> = 1.71 V, 500 mV from rail	–	–	–	–	
SID278	I <sub>OUT_MAX_HI</sub>	Power = high	4	–	–	mA	
SID279	I <sub>OUT_MAX_MID</sub>	Power = medium	4	–	–	mA	
SID280	I <sub>OUT_MAX_LO</sub>	Power = low	–	2	–	mA	
SID281	V <sub>IN</sub>	Charge pump on, V <sub>D<sub>DDA</sub></sub> ≥ 2.7 V	–0.05	–	V <sub>D<sub>DDA</sub></sub> – 0.2	V	
SID282	V <sub>CM</sub>	Charge pump on, V <sub>D<sub>DDA</sub></sub> ≥ 2.7 V	–0.05	–	V <sub>D<sub>DDA</sub></sub> – 0.2	V	
	V <sub>OUT</sub>	V <sub>D<sub>DDA</sub></sub> ≥ 2.7 V	–	–	–	–	
SID283	V <sub>OUT_1</sub>	Power = high, I <sub>load</sub> =10 mA	0.5	–	V <sub>D<sub>DDA</sub></sub> – 0.5	V	
SID284	V <sub>OUT_2</sub>	Power = high, I <sub>load</sub> =1 mA	0.2	–	V <sub>D<sub>DDA</sub></sub> – 0.2	V	
SID285	V <sub>OUT_3</sub>	Power = medium, I <sub>load</sub> =1 mA	0.2	–	V <sub>D<sub>DDA</sub></sub> – 0.2	V	
SID286	V <sub>OUT_4</sub>	Power = low, I <sub>load</sub> =0.1mA	0.2	–	V <sub>D<sub>DDA</sub></sub> – 0.2	V	
SID288	V <sub>OS_TR</sub>	Offset voltage, trimmed	1	±0.5	1	mV	High mode
SID288A	V <sub>OS_TR</sub>	Offset voltage, trimmed	–	±1	–	mV	Medium mode
SID288B	V <sub>OS_TR</sub>	Offset voltage, trimmed	–	±2	–	mV	Low mode
SID290	V <sub>OS_DR_TR</sub>	Offset voltage drift, trimmed	–10	±3	10	μV/C	High mode
SID290A	V <sub>OS_DR_TR</sub>	Offset voltage drift, trimmed	–	±10	–	μV/C	Medium mode
SID290B	V <sub>OS_DR_TR</sub>	Offset voltage drift, trimmed	–	±10	–	μV/C	Low mode
SID291	CMRR	DC	70	80	–	dB	V <sub>DDD</sub> = 3.6 V
SID292	PSRR	At 1 kHz, 100 mV ripple	70	85	–	dB	V <sub>DDD</sub> = 3.6 V
	Noise		–	–	–	–	
SID293	V <sub>N1</sub>	Input referred, 1 Hz - 1GHz, power = high	–	94	–	μV <sub>rms</sub>	
SID294	V <sub>N2</sub>	Input referred, 1 kHz, power = high	–	72	–	nV/ <sub>rt</sub> Hz	
SID295	V <sub>N3</sub>	Input referred, 10kHz, power = high	–	28	–	nV/ <sub>rt</sub> Hz	
SID296	V <sub>N4</sub>	Input referred, 100kHz, power = high	–	15	–	nV/ <sub>rt</sub> Hz	
SID297	Cload	Stable up to maximum load. Performance specs at 50 pF.	–	–	125	pF	

**Table 8. Opamp Specifications**

(Guaranteed by Characterization) (continued)

Spec ID#	Parameter	Description	Min	Typ	Max	Units	Details/ Conditions
SID298	Slew_rate	Cload = 50 pF, Power = High, $V_{DDA} \geq 2.7$ V	6	–	–	V/ $\mu$ sec	
SID299	T_op_wake	From disable to enable, no external RC dominating	–	300	–	$\mu$ sec	
	Comp_mode	Comparator mode; 50 mV drive, Trise = Tfall (approx.)	–	–	–		
SID300	T <sub>PD1</sub>	Response time; power = high	–	150	–	nsec	
SID301	T <sub>PD2</sub>	Response time; power = medium	–	400	–	nsec	
SID302	T <sub>PD3</sub>	Response time; power = low	–	2000	–	nsec	
SID303	Vhyst_op	Hysteresis	–	10	–	mV	

Comparator

**Table 9. Comparator DC Specifications**

Spec ID#	Parameter	Description	Min	Typ	Max	Units	Details/ Conditions
SID85	V <sub>OFFSET2</sub>	Input offset voltage	–	–	$\pm 4$	mV	
SID85A	V <sub>OFFSET3</sub>	Input offset voltage. Ultra low-power mode.	–	$\pm 12$	–	mV	
SID86	V <sub>HYST</sub>	Hysteresis when enabled	–	10	35	mV	Guaranteed by characterization
SID87	V <sub>ICM1</sub>	Input common mode voltage in normal mode	0	–	$V_{DDD} - 0.1$	V	Modes 1 and 2. Guaranteed by characterization
SID247	V <sub>ICM2</sub>	Input common mode voltage in low power mode	0	–	$V_{DDD}$	V	Guaranteed by characterization
SID247A	V <sub>ICM2</sub>	Input common mode voltage in ultra low power mode	0	–	$V_{DDD} - 1.15$	V	Guaranteed by characterization
SID88	CMRR	Common mode rejection ratio	50	–	–	dB	$V_{DDD} \geq 2.7$ V. Guaranteed by characterization
SID88A	CMRR	Common mode rejection ratio	42	–	–	dB	$V_{DDD} < 2.7$ V. Guaranteed by characterization
SID89	I <sub>CMP1</sub>	Block current, normal mode	–	–	280	$\mu$ A	Guaranteed by characterization
SID248	I <sub>CMP2</sub>	Block current, low power mode	–	–	50	$\mu$ A	Guaranteed by characterization
SID259	I <sub>CMP3</sub>	Block current, ultra low power mode	–	–	6	$\mu$ A	Guaranteed by characterization
SID90	Z <sub>CMP</sub>	DC input impedance of comparator	35	–	–	M $\Omega$	Guaranteed by characterization

**Table 10. Comparator AC Specifications**

(Guaranteed by Characterization)

Spec ID#	Parameter	Description	Min	Typ	Max	Units	Details/Conditions
SID91	T <sub>RESP1</sub>	Response time, normal mode	–	–	38	ns	50 mV overdrive
SID258	T <sub>RESP2</sub>	Response time, low power mode	–	–	70	ns	50 mV overdrive
SID92	T <sub>RESP3</sub>	Response time, ultra low power mode	–	–	2.3	µs	200 mV overdrive

Temperature Sensor

**Table 11. Temperature Sensor Specifications**

Spec ID#	Parameter	Description	Min	Typ	Max	Units	Details/Conditions
SID93	T <sub>SENSACC</sub>	Temperature sensor accuracy	–5	±1	+5	°C	–40 to +85 °C

SAR ADC

**Table 12. SAR ADC DC Specifications**

Spec ID#	Parameter	Description	Min	Typ	Max	Units	Details/Conditions
SID94	A_RES	Resolution	–	–	12	bits	
SID95	A_CHNIS_S	Number of channels - single ended	–	–	8		8 full speed
SID96	A-CHNKS_D	Number of channels - differential	–	–	4		Diff inputs use neighboring I/O
SID97	A-MONO	Monotonicity	–	–	–		Yes. Based on characterization
SID98	A_GAINERR	Gain error	–	–	±0.1	%	With external reference. Guaranteed by characterization
SID99	A_OFFSET	Input offset voltage	–	–	2	mV	Measured with 1-V V <sub>REF</sub> . Guaranteed by characterization
SID100	A_ISAR	Current consumption	–	–	1	mA	
SID101	A_VINS	Input voltage range - single ended	V <sub>SS</sub>	–	V <sub>DDA</sub>	V	Based on device characterization
SID102	A_VIND	Input voltage range - differential	V <sub>SS</sub>	–	V <sub>DDA</sub>	V	Based on device characterization
SID103	A_INRES	Input resistance	–	–	2.2	KΩ	Based on device characterization
SID104	A_INCAP	Input capacitance	–	–	10	pF	Based on device characterization

**Table 13. SAR ADC AC Specifications**

(Guaranteed by Characterization)

Spec ID#	Parameter	Description	Min	Typ	Max	Units	Details/Conditions
SID106	A_PSRR	Power supply rejection ratio	70	–	–	dB	
SID107	A_CMRR	Common mode rejection ratio	66	–	–	dB	Measured at 1 V
SID108	A_SAMP_1	Sample rate with external reference bypass cap	–	–	1	MSPS	

**Table 13. SAR ADC AC Specifications**

(Guaranteed by Characterization) (continued)

Spec ID#	Parameter	Description	Min	Typ	Max	Units	Details/Conditions
SID108A	A_SAMP_2	Sample rate with no bypass cap. Reference = V <sub>DD</sub>	–	–	500	Ksps	
SID108B	A_SAMP_3	Sample rate with no bypass cap. Internal reference	–	–	100	Ksps	
SID109	A_SNDR	Signal-to-noise and distortion ratio (SINAD)	65	–	–	dB	F <sub>IN</sub> = 10 kHz
SID111	A_INL	Integral non linearity	–1.7	–	+2	LSB	V <sub>DD</sub> = 1.71 to 5.5, 1 Msps, Vref = 1 to 5.5.
SID111A	A_INL	Integral non linearity	–1.5	–	+1.7	LSB	V <sub>DDD</sub> = 1.71 to 3.6, 1 Msps, Vref = 1.71 to V <sub>DDD</sub> .
SID111B	A_INL	Integral non linearity	–1.5	–	+1.7	LSB	V <sub>DDD</sub> = 1.71 to 5.5, 500 Ksps, Vref = 1 to 5.5.
SID112	A_DNL	Differential non linearity	–1	–	+2.2	LSB	V <sub>DDD</sub> = 1.71 to 5.5, 1 Msps, Vref = 1 to 5.5.
SID112A	A_DNL	Differential non linearity	–1	–	+2	LSB	V <sub>DDD</sub> = 1.71 to 3.6, 1 Msps, Vref = 1.71 to V <sub>DDD</sub> .
SID112B	A_DNL	Differential non linearity	–1	–	+2.2	LSB	V <sub>DDD</sub> = 1.71 to 5.5, 500 Ksps, Vref = 1 to 5.5.
SID113	A_THD	Total harmonic distortion	–	–	–65	dB	F <sub>IN</sub> = 10 kHz.

CSD

**Table 14. CSD Block Specification**

Spec ID#	Parameter	Description	Min	Typ	Max	Units	Details/Conditions
<b>CSD Specification</b>							
SID308	VCSD	Voltage range of operation	1.71	–	5.5	V	
SID309	IDAC1	DNL for 8-bit resolution	–1	–	1	LSB	
SID310	IDAC1	INL for 8-bit resolution	–3	–	3	LSB	
SID311	IDAC2	DNL for 7-bit resolution	–1	–	1	LSB	
SID312	IDAC2	INL for 7-bit resolution	–3	–	3	LSB	
SID313	SNR	Ratio of counts of finger to noise. Guaranteed by characterization	5	–	–	Ratio	Capacitance range of 9 to 35 pF, 0.1 pF sensitivity
SID314	IDAC1_CRT1	Output current of Idac1 (8-bits) in High range	–	612	–	μA	
SID314A	IDAC1_CRT2	Output current of Idac1(8-bits) in Low range	–	306	–	μA	
SID315	IDAC2_CRT1	Output current of Idac2 (7-bits) in High range	–	304.8	–	μA	
SID315A	IDAC2_CRT2	Output current of Idac2 (7-bits) in Low range	–	152.4	–	μA	

## Digital Peripherals

The following specifications apply to the Timer/Counter/PWM peripherals in the Timer mode.

### Timer

**Table 15. Timer DC Specifications**

(Guaranteed by Characterization)

Spec ID	Parameter	Description	Min	Typ	Max	Units	Details/Conditions
SID115	I <sub>TIM1</sub>	Block current consumption at 3 MHz	–	–	19	μA	16-bit timer
SID116	I <sub>TIM2</sub>	Block current consumption at 12 MHz	–	–	66	μA	16-bit timer
SID117	I <sub>TIM3</sub>	Block current consumption at 48 MHz	–	–	285	μA	16-bit timer

**Table 16. Timer AC Specifications**

(Guaranteed by Characterization)

Spec ID	Parameter	Description	Min	Typ	Max	Units	Details/Conditions
SID118	T <sub>TIMFREQ</sub>	Operating frequency	–	–	48	MHz	
SID119	T <sub>CAPWINT</sub>	Capture pulse width (internal)	42	–	–	ns	
SID120	T <sub>CAPWEXT</sub>	Capture pulse width (external)	42	–	–	ns	
SID121	T <sub>TIMRES</sub>	Timer resolution	21	–	–	ns	
SID122	T <sub>TENWIDINT</sub>	Enable pulse width (internal)	42	–	–	ns	
SID123	T <sub>TENWIDEXT</sub>	Enable pulse width (external)	42	–	–	ns	
SID124	T <sub>TIMRESWINT</sub>	Reset pulse width (internal)	42	–	–	ns	
SID125	T <sub>TIMRESEXT</sub>	Reset pulse width (external)	42	–	–	ns	

### Counter

**Table 17. Counter DC Specifications**

(Guaranteed by Characterization)

Spec ID	Parameter	Description	Min	Typ	Max	Units	Details/Conditions
SID126	I <sub>CTR1</sub>	Block current consumption at 3 MHz	–	–	19	μA	16-bit Counter
SID127	I <sub>CTR2</sub>	Block current consumption at 12 MHz	–	–	66	μA	16-bit Counter
SID128	I <sub>CTR3</sub>	Block current consumption at 48 MHz	–	–	285	μA	16-bit Counter

**Table 18. Counter AC Specifications**

(Guaranteed by Characterization)

Spec ID	Parameter	Description	Min	Typ	Max	Units	Details/Conditions
SID129	T <sub>CTRFREQ</sub>	Operating frequency	–	–	48	MHz	
SID130	T <sub>CTRPWINT</sub>	Capture pulse width (internal)	42	–	–	ns	
SID131	T <sub>CTRPWEXT</sub>	Capture pulse width (external)	42	–	–	ns	
SID132	T <sub>CTRES</sub>	Counter Resolution	21	–	–	ns	
SID133	T <sub>CENWIDINT</sub>	Enable pulse width (internal)	42	–	–	ns	
SID134	T <sub>CENWIDEXT</sub>	Enable pulse width (external)	42	–	–	ns	
SID135	T <sub>CTRRESWINT</sub>	Reset pulse width (internal)	42	–	–	ns	
SID136	T <sub>CTRRESWEXT</sub>	Reset pulse width (external)	42	–	–	ns	

*Pulse Width Modulation (PWM)*
**Table 19. PWM DC Specifications**

(Guaranteed by Characterization)

Spec ID	Parameter	Description	Min	Typ	Max	Units	Details/Conditions
SID137	I <sub>PWM1</sub>	Block current consumption at 3 MHz	–	–	19	μA	16-bit PWM
SID138	I <sub>PWM2</sub>	Block current consumption at 12 MHz	–	–	66	μA	16-bit PWM
SID139	I <sub>PWM3</sub>	Block current consumption at 48 MHz	–	–	285	μA	16-bit PWM

**Table 20. PWM AC Specifications**

(Guaranteed by Characterization)

Spec ID	Parameter	Description	Min	Typ	Max	Units	Details/Conditions
SID140	T <sub>PWMFREQ</sub>	Operating frequency	–	–	48	MHz	
SID141	T <sub>PWMPWINT</sub>	Pulse width (internal)	42	–	–	ns	
SID142	T <sub>PWMEXT</sub>	Pulse width (external)	42	–	–	ns	
SID143	T <sub>PWMKILLINT</sub>	Kill pulse width (internal)	42	–	–	ns	
SID144	T <sub>PWMKILLEXT</sub>	Kill pulse width (external)	42	–	–	ns	
SID145	T <sub>PWMEINT</sub>	Enable pulse width (internal)	42	–	–	ns	
SID146	T <sub>PWMENEXT</sub>	Enable pulse width (external)	42	–	–	ns	
SID147	T <sub>PWMRESWINT</sub>	Reset pulse width (internal)	42	–	–	ns	
SID148	T <sub>PWMRESWEXT</sub>	Reset pulse width (external)	42	–	–	ns	

*I<sup>2</sup>C*
**Table 21. Fixed I<sup>2</sup>C DC Specifications**

(Guaranteed by Characterization)

Spec ID	Parameter	Description	Min	Typ	Max	Units	Details/Conditions
SID149	I <sub>I2C1</sub>	Block current consumption at 100 kHz	–	–	10.5	μA	
SID150	I <sub>I2C2</sub>	Block current consumption at 400 kHz	–	–	135	μA	
SID151	I <sub>I2C3</sub>	Block current consumption at 1 Mbps	–	–	310	μA	
SID152	I <sub>I2C4</sub>	I <sup>2</sup> C enabled in Deep Sleep mode	–	–	1.4	μA	

**Table 22. Fixed I<sup>2</sup>C AC Specifications**

(Guaranteed by Characterization)

Spec ID	Parameter	Description	Min	Typ	Max	Units	Details/Conditions
SID153	F <sub>I2C1</sub>	Bit rate	–	–	1	Mbps	

*LCD Direct Drive*

**Table 23. LCD Direct Drive DC Specifications**

(Guaranteed by Characterization)

Spec ID	Parameter	Description	Min	Typ	Max	Units	Details/Conditions
SID154	I <sub>LCDLOW</sub>	Operating current in low power mode	–	5	–	μA	16 × 4 small segment disp. at 50 Hz
SID155	C <sub>LCDCAP</sub>	LCD capacitance per segment/common driver	–	500	5000	pF	Guaranteed by Design
SID156	LCD <sub>OFFSET</sub>	Long-term segment offset	–	20	–	mV	
SID157	I <sub>LCDOP1</sub>	PWM Mode current. 5-V bias. 24-MHz IMO. 25 °C	–	0.6	–	mA	32 × 4 segments. 50 Hz
SID158	I <sub>LCDOP2</sub>	PWM Mode current. 3.3-V bias. 24-MHz IMO. 25 °C	–	0.5	–	mA	32 × 4 segments. 50 Hz

**Table 24. LCD Direct Drive AC Specifications**

(Guaranteed by Characterization)

Spec ID	Parameter	Description	Min	Typ	Max	Units	Details/Conditions
SID159	F <sub>LCD</sub>	LCD frame rate	10	50	150	Hz	

**Table 25. Fixed UART DC Specifications**

(Guaranteed by Characterization)

Spec ID	Parameter	Description	Min	Typ	Max	Units	Details/Conditions
SID160	I <sub>UART1</sub>	Block current consumption at 100 Kbits/sec	–	–	9	μA	
SID161	I <sub>UART2</sub>	Block current consumption at 1000 Kbits/sec	–	–	312	μA	

**Table 26. Fixed UART AC Specifications**

(Guaranteed by Characterization)

Spec ID	Parameter	Description	Min	Typ	Max	Units
SID162	F <sub>UART</sub>	Bit rate	–	–	1	Mbps

*SPI Specifications*

**Table 27. Fixed SPI DC Specifications**

(Guaranteed by Characterization)

Spec ID	Parameter	Description	Min	Typ	Max	Units
SID163	I <sub>SPI1</sub>	Block current consumption at 1 Mb/s	–	–	360	μA
SID164	I <sub>SPI2</sub>	Block current consumption at 4 Mb/s	–	–	560	μA
SID165	I <sub>SPI3</sub>	Block current consumption at 8 Mb/s	–	–	600	μA

**Table 28. Fixed SPI AC Specifications**

(Guaranteed by Characterization)

Spec ID	Parameter	Description	Min	Typ	Max	Units
SID166	F <sub>SPI</sub>	SPI operating frequency (master; 6X oversampling)	–	–	8	MHz



**Table 29. Fixed SPI Master mode AC Specifications**

(Guaranteed by Characterization)

Spec ID	Parameter	Description	Min	Typ	Max	Units
SID167	T <sub>DMO</sub>	MOSI valid after Sclock driving edge	–	–	15	ns
SID168	T <sub>DSI</sub>	MISO valid before Sclock capturing edge. Full clock, late MISO Sampling used	20	–	–	ns
SID169	T <sub>HMO</sub>	Previous MOSI data hold time with respect to capturing edge at Slave	0	–	–	ns

**Table 30. Fixed SPI Slave mode AC Specifications**

(Guaranteed by Characterization)

Spec ID	Parameter	Description	Min	Typ	Max	Units
SID170	T <sub>DMI</sub>	MOSI valid before Sclock capturing edge	40	–	–	ns
SID171	T <sub>DSO</sub>	MISO valid after Sclock driving edge	–	–	42 + 3 × F <sub>CPU</sub>	ns
SID171A	T <sub>DSO_ext</sub>	MISO valid after Sclock driving edge in Ext. Clock mode	–	–	48	ns
SID172	T <sub>HSO</sub>	Previous MISO data hold time	0	–	–	ns
SID172A	T <sub>SSELSCK</sub>	SSEL Valid to first SCK Valid edge	100	–	–	ns

## Memory

**Table 31. Flash DC Specifications**

Spec ID	Parameter	Description	Min	Typ	Max	Units	Details/Conditions
SID173	V <sub>PE</sub>	Erase and program voltage	1.71	–	5.5	V	

**Table 32. Flash AC Specifications**

Spec ID	Parameter	Description	Min	Typ	Max	Units	Details/Conditions
SID174	T <sub>ROWWRITE</sub> <sup>[3]</sup>	Row (block) write time (erase and program)	–	–	20	ms	Row (block) = 128 bytes
SID175	T <sub>ROWERASE</sub> <sup>[3]</sup>	Row erase time	–	–	13	ms	
SID176	T <sub>ROWPROGRAM</sub> <sup>[3]</sup>	Row program time after erase	–	–	7	ms	
SID178	T <sub>BULKERASE</sub> <sup>[3]</sup>	Bulk erase time (32 KB)	–	–	35	ms	
SID180	T <sub>DEVPROG</sub> <sup>[3]</sup>	Total device program time	–	–	7	seconds	Guaranteed by characterization
SID181	F <sub>END</sub>	Flash endurance	100 K	–	–	cycles	Guaranteed by characterization
SID182	F <sub>RET</sub>	Flash retention. T <sub>A</sub> ≤ 55 °C, 100 K P/E cycles	20	–	–	years	Guaranteed by characterization
SID182A		Flash retention. T <sub>A</sub> ≤ 85 °C, 10 K P/E cycles	10	–	–	years	Guaranteed by characterization

### Note

- It can take as much as 20 milliseconds to write to Flash. During this time the device should not be Reset, or Flash operations will be interrupted and cannot be relied on to have completed. Reset sources include the XRES pin, software resets, CPU lockup states and privilege violations, improper power supply levels, and watchdogs. Make certain that these are not inadvertently activated.

## System Resources

Power-on-Reset (POR) with Brown Out

**Table 33. Imprecise Power On Reset (PRES)**

Spec ID	Parameter	Description	Min	Typ	Max	Units	Details/Conditions
SID185	V <sub>RISEIPOR</sub>	Rising trip voltage	0.80	–	1.45	V	Guaranteed by characterization
SID186	V <sub>FALLIPOR</sub>	Falling trip voltage	0.75	–	1.4	V	Guaranteed by characterization
SID187	V <sub>IPOHYST</sub>	Hysteresis	15	–	200	mV	Guaranteed by characterization

**Table 34. Precise Power On Reset (POR)**

Spec ID	Parameter	Description	Min	Typ	Max	Units	Details/Conditions
SID190	V <sub>FALLPPOR</sub>	BOD trip voltage in active and sleep modes	1.64	–	–	V	Guaranteed by characterization
SID192	V <sub>FALLDPSLP</sub>	BOD trip voltage in Deep Sleep	1.4	–	–	V	Guaranteed by characterization

Voltage Monitors

**Table 35. Voltage Monitors DC Specifications**

Spec ID	Parameter	Description	Min	Typ	Max	Units	Details/Conditions
SID195	V <sub>LVI1</sub>	LVI_A/D_SEL[3:0] = 0000b	1.71	1.75	1.79	V	
SID196	V <sub>LVI2</sub>	LVI_A/D_SEL[3:0] = 0001b	1.76	1.80	1.85	V	
SID197	V <sub>LVI3</sub>	LVI_A/D_SEL[3:0] = 0010b	1.85	1.90	1.95	V	
SID198	V <sub>LVI4</sub>	LVI_A/D_SEL[3:0] = 0011b	1.95	2.00	2.05	V	
SID199	V <sub>LVI5</sub>	LVI_A/D_SEL[3:0] = 0100b	2.05	2.10	2.15	V	
SID200	V <sub>LVI6</sub>	LVI_A/D_SEL[3:0] = 0101b	2.15	2.20	2.26	V	
SID201	V <sub>LVI7</sub>	LVI_A/D_SEL[3:0] = 0110b	2.24	2.30	2.36	V	
SID202	V <sub>LVI8</sub>	LVI_A/D_SEL[3:0] = 0111b	2.34	2.40	2.46	V	
SID203	V <sub>LVI9</sub>	LVI_A/D_SEL[3:0] = 1000b	2.44	2.50	2.56	V	
SID204	V <sub>LVI10</sub>	LVI_A/D_SEL[3:0] = 1001b	2.54	2.60	2.67	V	
SID205	V <sub>LVI11</sub>	LVI_A/D_SEL[3:0] = 1010b	2.63	2.70	2.77	V	
SID206	V <sub>LVI12</sub>	LVI_A/D_SEL[3:0] = 1011b	2.73	2.80	2.87	V	
SID207	V <sub>LVI13</sub>	LVI_A/D_SEL[3:0] = 1100b	2.83	2.90	2.97	V	
SID208	V <sub>LVI14</sub>	LVI_A/D_SEL[3:0] = 1101b	2.93	3.00	3.08	V	
SID209	V <sub>LVI15</sub>	LVI_A/D_SEL[3:0] = 1110b	3.12	3.20	3.28	V	
SID210	V <sub>LVI16</sub>	LVI_A/D_SEL[3:0] = 1111b	4.39	4.50	4.61	V	
SID211	LVI_IDD	Block current	–	–	100	μA	Guaranteed by characterization

**Table 36. Voltage Monitors AC Specifications**

Spec ID	Parameter	Description	Min	Typ	Max	Units	Details/Conditions
SID212	T <sub>MONTRIP</sub>	Voltage monitor trip time	–	–	1	μs	Guaranteed by characterization

SWD Interface

**Table 37. SWD Interface Specifications**

Spec ID	Parameter	Description	Min	Typ	Max	Units	Details/Conditions
SID213	F_SWCLK1	$3.3\text{ V} \leq V_{DD} \leq 5.5\text{ V}$	–	–	14	MHz	SWDCLK $\leq$ 1/3 CPU clock frequency
SID214	F_SWCLK2	$1.71\text{ V} \leq V_{DD} \leq 3.3\text{ V}$	–	–	7	MHz	SWDCLK $\leq$ 1/3 CPU clock frequency
SID215	T_SWDI_SETUP	$T = 1/f$ SWDCLK	0.25*T	–	–	ns	Guaranteed by characterization
SID216	T_SWDI_HOLD	$T = 1/f$ SWDCLK	0.25*T	–	–	ns	Guaranteed by characterization
SID217	T_SWDO_VALID	$T = 1/f$ SWDCLK	–	–	0.5*T	ns	Guaranteed by characterization
SID217A	T_SWDO_HOLD	$T = 1/f$ SWDCLK	1	–	–	ns	Guaranteed by characterization

Internal Main Oscillator

**Table 38. IMO DC Specifications**

(Guaranteed by Design)

Spec ID	Parameter	Description	Min	Typ	Max	Units	Details/Conditions
SID218	I <sub>IMO1</sub>	IMO operating current at 48 MHz	–	–	1000	μA	
SID219	I <sub>IMO2</sub>	IMO operating current at 24 MHz	–	–	325	μA	
SID220	I <sub>IMO3</sub>	IMO operating current at 12 MHz	–	–	225	μA	
SID221	I <sub>IMO4</sub>	IMO operating current at 6 MHz	–	–	180	μA	
SID222	I <sub>IMO5</sub>	IMO operating current at 3 MHz	–	–	150	μA	

**Table 39. IMO AC Specifications**

Spec ID	Parameter	Description	Min	Typ	Max	Units	Details/Conditions
SID223	F <sub>IMOTOL1</sub>	Frequency variation from 3 to 48 MHz	–	–	±2	%	With API-called calibration
SID226	T <sub>STARTIMO</sub>	IMO startup time	–	–	12	μs	
SID227	T <sub>JITRMSIMO1</sub>	RMS Jitter at 3 MHz	–	156	–	ps	
SID228	T <sub>JITRMSIMO2</sub>	RMS Jitter at 24 MHz	–	145	–	ps	
SID229	T <sub>JITRMSIMO3</sub>	RMS Jitter at 48 MHz	–	139	–	ps	

Internal Low-Speed Oscillator

**Table 40. ILO DC Specifications**

(Guaranteed by Design)

Spec ID	Parameter	Description	Min	Typ	Max	Units	Details/Conditions
SID231	I <sub>ILO1</sub>	ILO operating current at 32 kHz	–	0.3	1.05	μA	Guaranteed by Characterization
SID233	I <sub>ILOLEAK</sub>	ILO leakage current	–	2	15	nA	Guaranteed by Design

**Table 41. ILO AC Specifications**

Spec ID	Parameter	Description	Min	Typ	Max	Units	Details/Conditions
SID234	T <sub>STARTILO1</sub>	ILO startup time	–	–	2	ms	Guaranteed by characterization
SID236	T <sub>ILODUTY</sub>	ILO duty cycle	40	50	60	%	Guaranteed by characterization
SID237	F <sub>ILOTRIM1</sub>	32 kHz trimmed frequency	15	32	50	kHz	±60% with trim.

**Table 42. External Clock Specifications**

Spec ID	Parameter	Description	Min	Typ	Max	Units	Details/Conditions
SID305	ExtClkFreq	External Clock input Frequency	0	–	48	MHz	Guaranteed by characterization
SID306	ExtClkDuty	Duty cycle; Measured at V <sub>DD/2</sub>	45	–	55	%	Guaranteed by characterization

**Table 43. UDB AC Specifications**

(Guaranteed by Characterization)

Spec ID	Parameter	Description	Min	Typ	Max	Units	Details/Conditions
<b>Datapath performance</b>							
SID249	F <sub>MAX-TIMER</sub>	Max frequency of 16-bit timer in a UDB pair	–	–	48	MHz	
SID250	F <sub>MAX-ADDER</sub>	Max frequency of 16-bit adder in a UDB pair	–	–	48	MHz	
SID251	F <sub>MAX_CRC</sub>	Max frequency of 16-bit CRC/PRS in a UDB pair	–	–	48	MHz	
<b>PLD Performance in UDB</b>							
SID252	F <sub>MAX_PLD</sub>	Max frequency of 2-pass PLD function in a UDB pair	–	–	48	MHz	
<b>Clock to Output Performance</b>							
SID253	T <sub>CLK_OUT_UBD1</sub>	Prop. delay for clock in to data out at 25 °C, Typ.	–	15	–	ns	
SID254	T <sub>CLK_OUT_UBD2</sub>	Prop. delay for clock in to data out, Worst case.	–	25	–	ns	

**Table 44. Block Specs**

Spec ID	Parameter	Description	Min	Typ	Max	Units	Details/Conditions
SID256*	T <sub>WS48</sub> *	Number of wait states at 48 MHz	1	–	–		CPU execution from Flash. Guaranteed by characterization
SID257	T <sub>WS24</sub> *	Number of wait states at 24 MHz	0	–	–		CPU execution from Flash. Guaranteed by characterization
SID260	V <sub>REFSAR</sub>	Trimmed internal reference to SAR	–1	–	+1	%	Percentage of V <sub>bg</sub> (1.024 V). Guaranteed by characterization
SID262	T <sub>CLKSWITCH</sub>	Clock switching from clk1 to clk2 in clk1 periods	3	–	4	Periods	. Guaranteed by design
* Tws48 and Tws24 are guaranteed by Design							

**Table 45. UDB Port Adaptor Specifications**

 (Based on LPC Component Specs, Guaranteed by Characterization -10-pF load, 3-V  $V_{DDIO}$  and  $V_{DDD}$ )

Spec ID	Parameter	Description	Min	Typ	Max	Units	Details/Conditions
SID263	$T_{LCLKDO}$	LCLK to output delay	–	–	18	ns	
SID264	$T_{DINLCLK}$	Input setup time to LCLK rising edge	–	–	7	ns	
SID265	$T_{DINLCLKHLD}$	Input hold time from LCLK rising edge	5	–	–	ns	
SID266	$T_{LCLKHIZ}$	LCLK to output tristated	–	–	28	ns	
SID267	$T_{FLCLK}$	LCLK frequency	–	–	33	MHz	
SID268	$T_{LCLKDUTY}$	LCLK duty cycle (percentage high)	40	–	60	%	

## Ordering Information

The PSoC 4200 part numbers and features are listed in the following table.

**Table 46. PSoC 4200 Family Ordering Information**

Family	MPN	Features											Package			Silicon ID	
		Max CPU Speed (MHz)	Flash (KB)	SRAM (KB)	UDB	Op-amp (CTBm)	CapSense	Direct LCD Drive	12-bit SAR ADC	LP Comparators	TCPWM Blocks	SCB Blocks	GPIO	28-SSOP	40-QFN		44-TQFP
4200	CY8C4244PVI-432	48	16	4	2	1	-	-	1 Msps	2	4	2	24	✓	-	-	04F0
	CY8C4244PVI-442	48	16	4	2	1	✓	✓	1 Msps	2	4	2	24	✓	-	-	04F1
	CY8C4244LQI-443	48	16	4	2	2	✓	✓	1 Msps	2	4	2	34	-	✓	-	04F6
	CY8C4244AXI-443	48	16	4	2	2	✓	✓	1 Msps	2	4	2	36	-	-	✓	04FA
	CY8C4245AXI-473	48	32	4	4	2	-	-	1 Msps	2	4	2	36	-	-	✓	04FB
	CY8C4245PVI-482	48	32	4	4	1	✓	✓	1 Msps	2	4	2	24	✓	-	-	04A6
	CY8C4245LQI-483	48	32	4	4	2	✓	✓	1 Msps	2	4	2	34	-	✓	-	04B6
	CY8C4245AXI-483	48	32	4	4	2	✓	✓	1 Msps	2	4	2	36	-	-	✓	04C8

**Part Numbering Conventions**

PSoC 4 devices follow the part numbering convention described in the following table. All fields are single-character alphanumeric (0, 1, 2, ..., 9, A,B, ..., Z) unless stated otherwise.

The part numbers are of the form CY8C4ABCDEF-XYZ where the fields are defined as follows.

**Example**

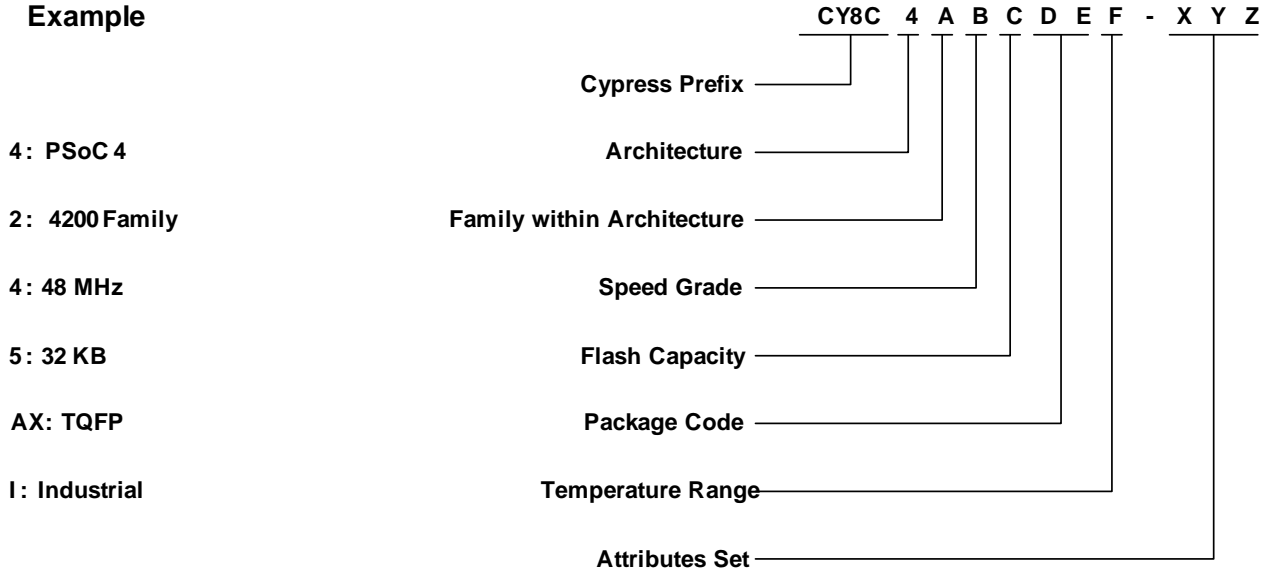

The Field Values are listed in the following table.

Field	Description	Values	Meaning
CY8C	Cypress Prefix		
4	Architecture	4	PSoC 4
A	Family within architecture	1	4100 Family
		2	4200 Family
B	CPU Speed	2	24 MHz
		4	48 MHz
C	Flash Capacity	4	16 KB
		5	32 KB
DE	Package Code	AX	TQFP
		LQ	QFN
		PV	SSOP
F	Temperature Range	I	Industrial
XYZ	Attributes Code	000-999	Code of feature set in specific family

## Packaging

Table 47. Package Characteristics

Parameter	Description	Conditions	Min	Typ	Max	Units
T <sub>A</sub>	Operating ambient temperature		-40	25.00	85	°C
T <sub>J</sub>	Operating junction temperature		-40	-	100	°C
T <sub>JA</sub>	Package θ <sub>JA</sub> (28-pin SSOP)		-	66.58	-	°C/Watt
T <sub>JA</sub>	Package θ <sub>JA</sub> (40-pin QFN)		-	15.34	-	°C/Watt
T <sub>JA</sub>	Package θ <sub>JA</sub> (44-pin TQFP)		-	57.16	-	°C/Watt
T <sub>JC</sub>	Package θ <sub>JC</sub> (28-pin SSOP)		-	26.28	-	°C/Watt
T <sub>JC</sub>	Package θ <sub>JC</sub> (40-pin QFN)		-	2.50	-	°C/Watt
T <sub>JC</sub>	Package θ <sub>JC</sub> (44-pin TQFP)		-	17.47	-	°C/Watt

Table 48. Solder Reflow Peak Temperature

Package	Maximum Peak Temperature	Maximum Time at Peak Temperature
28-pin SSOP	260 °C	30 seconds
40-pin QFN	260 °C	30 seconds
44-pin TQFP	260 °C	30 seconds

Table 49. Package Moisture Sensitivity Level (MSL), IPC/JEDEC J-STD-2

Package	MSL
28-pin SSOP	MSL 3
40-pin QFN	MSL 3
44-pin TQFP	MSL 3

Figure 12. 28-pin (210-mil) SSOP Package Outline

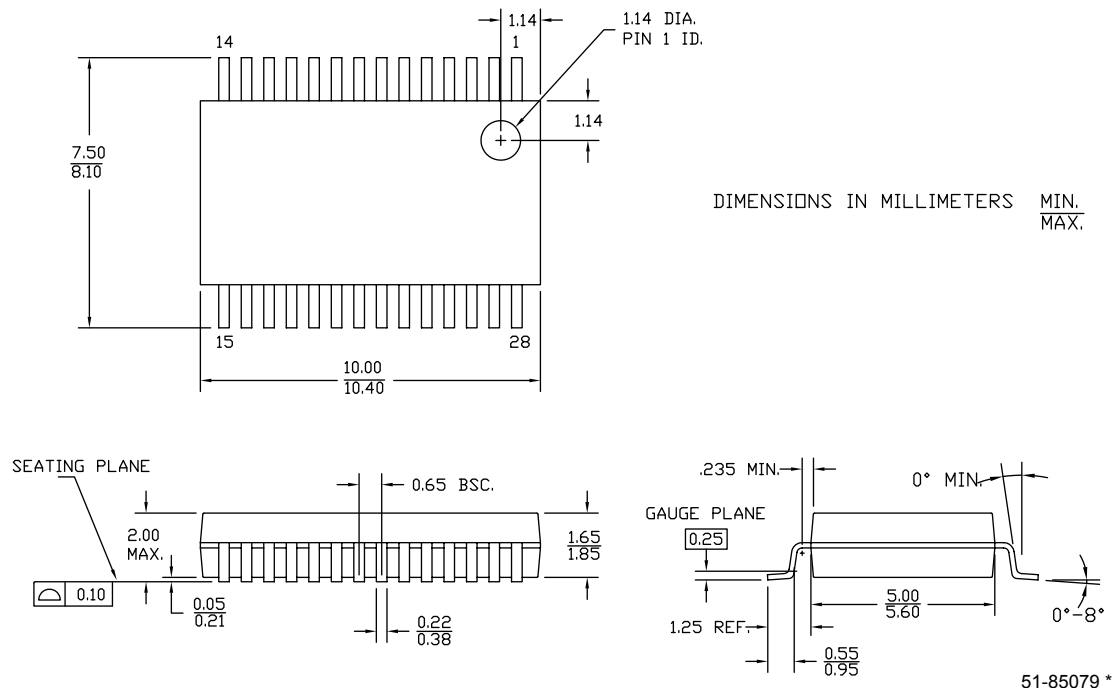



**Figure 13. 40-pin QFN Package Outline**

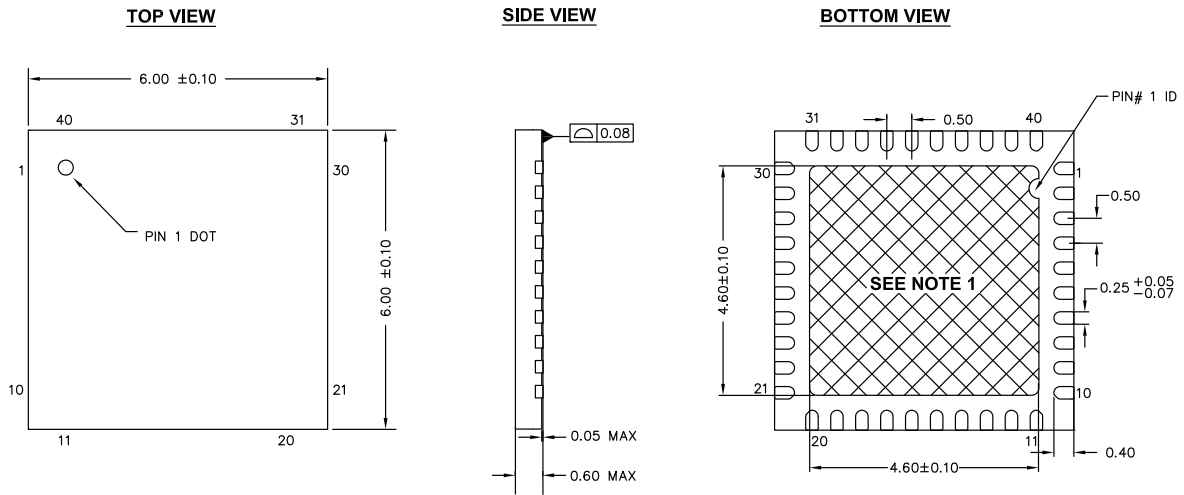

**NOTES:**

1. HATCH AREA IS SOLDERABLE EXPOSED PAD
2. REFERENCE JEDEC # MO-248
3. PACKAGE WEIGHT:  $68 \pm 2$  mg
4. ALL DIMENSIONS ARE IN MILLIMETERS

001-80659 \*\*

The center pad on the QFN package should be connected to ground (VSS) for best mechanical, thermal, and electrical performance. If not connected to ground, it should be electrically floating and not connected to any other signal.

**Figure 14. 44-pin TQFP Package Outline**

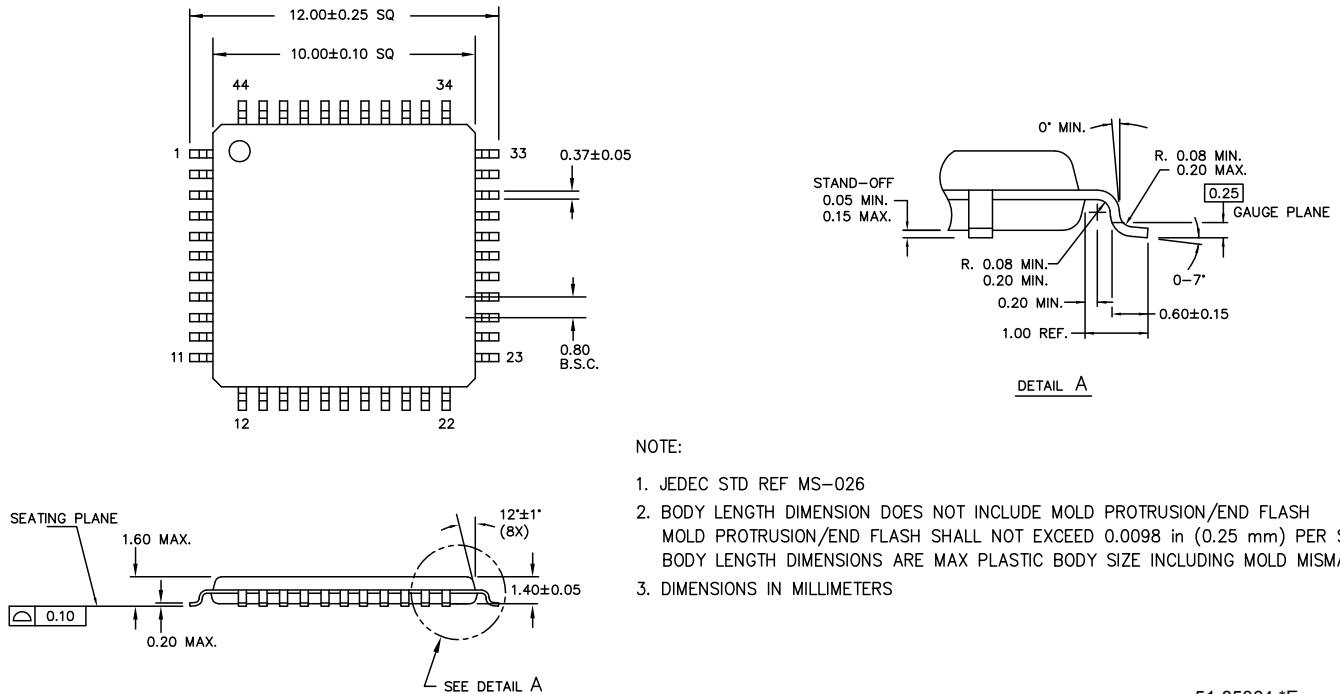

**NOTE:**

1. JEDEC STD REF MS-026
2. BODY LENGTH DIMENSION DOES NOT INCLUDE MOLD PROTRUSION/END FLASH  
 MOLD PROTRUSION/END FLASH SHALL NOT EXCEED 0.0098 in (0.25 mm) PER SIDE  
 BODY LENGTH DIMENSIONS ARE MAX PLASTIC BODY SIZE INCLUDING MOLD MISMATCH
3. DIMENSIONS IN MILLIMETERS

51-85064 \*E

## Acronyms

**Table 50. Acronyms Used in this Document**

Acronym	Description
abus	analog local bus
ADC	analog-to-digital converter
AG	analog global
AHB	AMBA (advanced microcontroller bus architecture) high-performance bus, an ARM data transfer bus
ALU	arithmetic logic unit
AMUXBUS	analog multiplexer bus
API	application programming interface
APSR	application program status register
ARM <sup>®</sup>	advanced RISC machine, a CPU architecture
ATM	automatic thump mode
BW	bandwidth
CAN	Controller Area Network, a communications protocol
CMRR	common-mode rejection ratio
CPU	central processing unit
CRC	cyclic redundancy check, an error-checking protocol
DAC	digital-to-analog converter, see also IDAC, VDAC
DFB	digital filter block
DIO	digital input/output, GPIO with only digital capabilities, no analog. See GPIO.
DMIPS	Dhrystone million instructions per second
DMA	direct memory access, see also TD
DNL	differential nonlinearity, see also INL
DNU	do not use
DR	port write data registers
DSI	digital system interconnect
DWT	data watchpoint and trace
ECC	error correcting code
ECO	external crystal oscillator
EEPROM	electrically erasable programmable read-only memory
EMI	electromagnetic interference
EMIF	external memory interface
EOC	end of conversion
EOF	end of frame
EPSR	execution program status register
ESD	electrostatic discharge

**Table 50. Acronyms Used in this Document (continued)**

Acronym	Description
ETM	embedded trace macrocell
FIR	finite impulse response, see also IIR
FPB	flash patch and breakpoint
FS	full-speed
GPIO	general-purpose input/output, applies to a PSoC pin
HVI	high-voltage interrupt, see also LVI, LVD
IC	integrated circuit
IDAC	current DAC, see also DAC, VDAC
IDE	integrated development environment
I <sup>2</sup> C, or IIC	Inter-Integrated Circuit, a communications protocol
IIR	infinite impulse response, see also FIR
ILO	internal low-speed oscillator, see also IMO
IMO	internal main oscillator, see also ILO
INL	integral nonlinearity, see also DNL
I/O	input/output, see also GPIO, DIO, SIO, USBIO
IPOR	initial power-on reset
IPSR	interrupt program status register
IRQ	interrupt request
ITM	instrumentation trace macrocell
LCD	liquid crystal display
LIN	Local Interconnect Network, a communications protocol.
LR	link register
LUT	lookup table
LVD	low-voltage detect, see also LVI
LVI	low-voltage interrupt, see also HVI
LVTTTL	low-voltage transistor-transistor logic
MAC	multiply-accumulate
MCU	microcontroller unit
MISO	master-in slave-out
NC	no connect
NMI	nonmaskable interrupt
NRZ	non-return-to-zero
NVIC	nested vectored interrupt controller
NVL	nonvolatile latch, see also WOL
opamp	operational amplifier
PAL	programmable array logic, see also PLD

**Table 50. Acronyms Used in this Document** *(continued)*

Acronym	Description
PC	program counter
PCB	printed circuit board
PGA	programmable gain amplifier
PHUB	peripheral hub
PHY	physical layer
PICU	port interrupt control unit
PLA	programmable logic array
PLD	programmable logic device, see also PAL
PLL	phase-locked loop
PMDD	package material declaration data sheet
POR	power-on reset
PRES	precise power-on reset
PRS	pseudo random sequence
PS	port read data register
PSoC <sup>®</sup>	Programmable System-on-Chip™
PSRR	power supply rejection ratio
PWM	pulse-width modulator
RAM	random-access memory
RISC	reduced-instruction-set computing
RMS	root-mean-square
RTC	real-time clock
RTL	register transfer language
RTR	remote transmission request
RX	receive
SAR	successive approximation register
SC/CT	switched capacitor/continuous time
SCL	I <sup>2</sup> C serial clock
SDA	I <sup>2</sup> C serial data
S/H	sample and hold
SINAD	signal to noise and distortion ratio
SIO	special input/output, GPIO with advanced features. See GPIO.
SOC	start of conversion
SOF	start of frame
SPI	Serial Peripheral Interface, a communications protocol
SR	slew rate
SRAM	static random access memory
SRES	software reset
SWD	serial wire debug, a test protocol

**Table 50. Acronyms Used in this Document** *(continued)*

Acronym	Description
SWV	single-wire viewer
TD	transaction descriptor, see also DMA
THD	total harmonic distortion
TIA	transimpedance amplifier
TRM	technical reference manual
TTL	transistor-transistor logic
TX	transmit
UART	Universal Asynchronous Transmitter Receiver, a communications protocol
UDB	universal digital block
USB	Universal Serial Bus
USBIO	USB input/output, PSoC pins used to connect to a USB port
VDAC	voltage DAC, see also DAC, IDAC
WDT	watchdog timer
WOL	write once latch, see also NVL
WRES	watchdog timer reset
XRES	external reset I/O pin
XTAL	crystal

## Document Conventions

### Units of Measure

**Table 51. Units of Measure**

Symbol	Unit of Measure
°C	degrees Celsius
dB	decibel
fF	femto farad
Hz	hertz
KB	1024 bytes
kbps	kilobits per second
Khr	kilohour
kHz	kilohertz
kΩ	kilo ohm
ksps	kilosamples per second
LSB	least significant bit
Mbps	megabits per second
MHz	megahertz
MΩ	mega-ohm
Msps	megasamples per second
μA	microampere
μF	microfarad
μH	microhenry
μs	microsecond
μV	microvolt
μW	microwatt
mA	milliampere
ms	millisecond
mV	millivolt
nA	nanoampere
ns	nanosecond
nV	nanovolt
Ω	ohm
pF	picofarad
ppm	parts per million
ps	picosecond
s	second
sps	samples per second
sqrtHz	square root of hertz
V	volt

**Revision History**

Description Title: PSoC <sup>®</sup> 4: PSoC 4200 Family Datasheet Programmable System-on-Chip (PSoC <sup>®</sup> ) Document Number: 001-87197				
Revision	ECN	Orig. of Change	Submission Date	Description of Change
*B	4108562	WKA	08/29/2013	Added clarifying note about the XRES pin in the <a href="#">Reset</a> section. Updated <a href="#">UDB Array</a> diagram. Added a link reference to the PSoC 4 TRM. Updated the footnote in <a href="#">Absolute Maximum Ratings</a> . Updated Sleep Mode IDD specs in <a href="#">DC Specifications</a> . Updated <a href="#">Comparator DC Specifications</a> Updated <a href="#">SAR ADC AC Specifications</a> Updated <a href="#">LCD Direct Drive DC Specifications</a> Updated the number of GPIOs in <a href="#">Ordering Information</a> .

## Sales, Solutions, and Legal Information

### Worldwide Sales and Design Support

Cypress maintains a worldwide network of offices, solution centers, manufacturer's representatives, and distributors. To find the office closest to you, visit us at [Cypress Locations](#).

#### Products

Automotive	<a href="http://cypress.com/go/automotive">cypress.com/go/automotive</a>
Clocks & Buffers	<a href="http://cypress.com/go/clocks">cypress.com/go/clocks</a>
Interface	<a href="http://cypress.com/go/interface">cypress.com/go/interface</a>
Lighting & Power Control	<a href="http://cypress.com/go/powerpsoc">cypress.com/go/powerpsoc</a> <a href="http://cypress.com/go/plc">cypress.com/go/plc</a>
Memory	<a href="http://cypress.com/go/memory">cypress.com/go/memory</a>
PSoC	<a href="http://cypress.com/go/psoc">cypress.com/go/psoc</a>
Touch Sensing	<a href="http://cypress.com/go/touch">cypress.com/go/touch</a>
USB Controllers	<a href="http://cypress.com/go/USB">cypress.com/go/USB</a>
Wireless/RF	<a href="http://cypress.com/go/wireless">cypress.com/go/wireless</a>

#### PSoC<sup>®</sup> Solutions

[psoc.cypress.com/solutions](http://psoc.cypress.com/solutions)  
PSoC 1 | PSoC 3 | PSoC 4 | PSoC 5LP

#### Cypress Developer Community

[Community](#) | [Forums](#) | [Blogs](#) | [Video](#) | [Training](#)

#### Technical Support

[cypress.com/go/support](http://cypress.com/go/support)

---

© Cypress Semiconductor Corporation, 2013. The information contained herein is subject to change without notice. Cypress Semiconductor Corporation assumes no responsibility for the use of any circuitry other than circuitry embodied in a Cypress product. Nor does it convey or imply any license under patent or other rights. Cypress products are not warranted nor intended to be used for medical, life support, life saving, critical control or safety applications, unless pursuant to an express written agreement with Cypress. Furthermore, Cypress does not authorize its products for use as critical components in life-support systems where a malfunction or failure may reasonably be expected to result in significant injury to the user. The inclusion of Cypress products in life-support systems application implies that the manufacturer assumes all risk of such use and in doing so indemnifies Cypress against all charges.

Any Source Code (software and/or firmware) is owned by Cypress Semiconductor Corporation (Cypress) and is protected by and subject to worldwide patent protection (United States and foreign), United States copyright laws and international treaty provisions. Cypress hereby grants to licensee a personal, non-exclusive, non-transferable license to copy, use, modify, create derivative works of, and compile the Cypress Source Code and derivative works for the sole purpose of creating custom software and or firmware in support of licensee product to be used only in conjunction with a Cypress integrated circuit as specified in the applicable agreement. Any reproduction, modification, translation, compilation, or representation of this Source Code except as specified above is prohibited without the express written permission of Cypress.

Disclaimer: CYPRESS MAKES NO WARRANTY OF ANY KIND, EXPRESS OR IMPLIED, WITH REGARD TO THIS MATERIAL, INCLUDING, BUT NOT LIMITED TO, THE IMPLIED WARRANTIES OF MERCHANTABILITY AND FITNESS FOR A PARTICULAR PURPOSE. Cypress reserves the right to make changes without further notice to the materials described herein. Cypress does not assume any liability arising out of the application or use of any product or circuit described herein. Cypress does not authorize its products for use as critical components in life-support systems where a malfunction or failure may reasonably be expected to result in significant injury to the user. The inclusion of Cypress' product in a life-support systems application implies that the manufacturer assumes all risk of such use and in doing so indemnifies Cypress against all charges.

Use may be limited by and subject to the applicable Cypress software license agreement.